

INDEX

RoHS compliance
(ALL products)

DC MOTOR WITH BRUSHES

TGU16-L	1
TGU16-S	2

D-SERIES BEARINGS

DR-A	7
DR-B	8
DR-H	10
DO-A, B, H	11
DU-A, B, H	12
DV-A, B, H	13
DF-B, H	14
DH-A, B, H	14

D-SERIES ROLLERS

DL-A, B	15
---------	----

I-SERIES BEARINGS

IDS-A, B, H	16
IN-A, B	17
ID-A, B	17

A-SERIES BEARINGS

A-A, B, H	18
-----------	----

TPF/THF-SERIES BEARINGS

TPF	19
THF	21

C/PE/PK/PV/S-SERIES BEARINGS

C CERAMIC	23
S DR-A, B, H	24
PK/PV	25
PE	26
S SUS	27

MISCELLANEOUS BEARING SERIES

28

SLIDING DOOR WHEELS

30

K-SERIES BEARINGS

32

ONE-WAY CLUTCHES

33

TORQUE LIMITERS

37

ROTARY-DAMPERS

41

PLALINEAR (LINEAR BEARING)/PLALINEAR MOTION (LINEAR MOTION)

61



HEAD OFFICE



YAMANASHI PLANT



TOK INDUSTRY CONSIGNMENT FACTORY



SHANGHAI TOK PRECISION DAMPER BEARING CO., LTD

Introduction

Since the development of our first "D" series plastic (polyacetal) ball bearings in 1964, TOK BEARING has been a world leader in the design and production of plastic bearings. Our reputation stretches from the office furniture industry, electric appliance industry, office automation equipment industry and many others. TOK BEARING is proud of its high level of quality, customer service, and reliability.

In addition to bearings, TOK BEARING also design and manufactures Uni-directional clutches ; Torque limiters ; Rotary dampers ; and other mechanical and motion components.

Our customers thoughts and ideas are important to us, and were used in the development of the TPF/THF bearings, PK/PV bearings, and the Miniature bearings.

Our engineering and design departments will continue to develop new cutting edge technologies for our customers. Let us help you on your next design.

TOK BEARING CO., LTD

A WORLD LEADER IN MECHANICAL AND MOTION TECHNOLOGIES



D-SERIES BEARINGS



PK-SERIES BEARINGS



S-SERIES BEARINGS



TPF/THF BEARINGS



UNI-DIRECTIONAL CLUTCHES



TORQUE LIMITERS



ROTARY DAMPERS



PLALINEAR/
PLALINEAR MOTION

GEARED MOTORS

TGU16-L

TGU16-L

(DC Motor with Brushes)



Dimensions

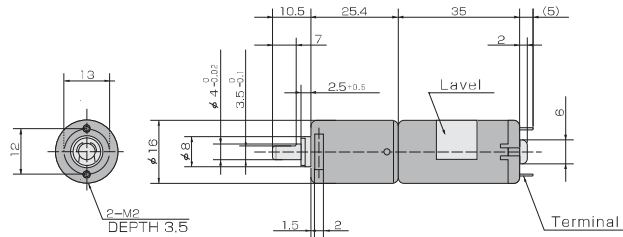

Applications

Game machines, Automatic Teller machines (ATM), Door locks, Convey equipment, automatic and electrical curtains, Duplicators, and Robotics.

Standard specifications for Gearhead

Reduction ratio	Gear stages	Allowable Torque		Moment maximum load		Allowable radial load N	Allowable axial load N
		mN·m	kgf·cm	mN·m	kgf·cm		
15~26	2	49	0.5	73.5	0.75	4.9	4.9
59~133	3	98	1.0	147.0	1.5	4.9	4.9

Characteristic for Geared Motor

Part No				TGU16-24L (24V type)						TGU16-12L (12V type)					
Reduction ratio	Gear stages	Direction	Weight g	No-load		Rating				No-load		Rating			
				Rev.	Current	Torque		Rev.	Current	Rev.	Current	Torque		Rev.	Current
				r/min	mA	mN·m	kgf·cm	r/min	mA	r/min	mA	mN·m	kgf·cm	r/min	mA
15	2	CCW	51	828	55	9.8	0.1	759	102	622	65	9.8	0.1	560	136
20				633	55	9.8	0.1	593	91	476	65	9.8	0.1	439	119
26				484	55	19.6	0.2	437	110	364	65	19.6	0.2	321	148
59	3		52	212	55	49	0.5	187	122	160	65	49	0.5	137	166
78				162	55	58.8	0.6	145	117	122	65	58.8	0.6	106	158
101				124	55	78.4	0.8	110	118	93.3	65	78.4	0.8	80.8	160
133		94.9		55	98	1.0	84.8	115	71.4	65	98	1.0	62.2	155	

Standard specifications for motor

Type No.	Voltage V	No-load		Rating				Starting			Weight g	Brush	Noise element	
		Rev.	Current	Output	Torque		Rev.	Current	Torque	Current				
		r/min	mA	W	mN·m	gf·cm	r/min	mA	mN·m	gf·cm				mA
TP-1635B-24	DC24	13,300	35	1.4	1.18	12	11,600	110	9.20	93.9	621.8	27	Carbon	Varistor
TP-1635C-12	DC12	10,000	40	1.28	1.18	12	8,500	150	7.84	80.0	773.3	27	Carbon	Varistor

TOK BEARING CO.,LTD.

HEAD OFFICE, TOKYO, JAPAN - TEL : 81-3-3969-1534 FAX : 81-3-3969-9354
EMAIL : overseas@tok-bearing.co.jp

Product specification are subject to change without prior notice.

Before assembly or use of any bearing, please read "Caution for Use"

GEARED MOTORS

TGU16-S

TGU16-S

(DC Motor with Brushes)



Dimensions

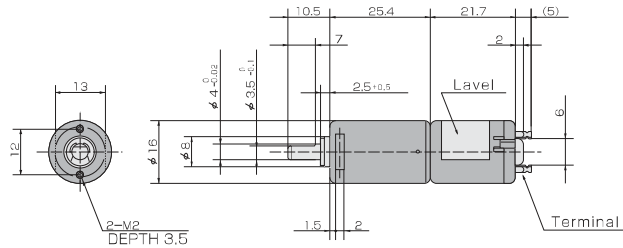

Applications

Game machines, Automatic Teller machines (ATM), Door locks, Convey equipment, automatic and electrical curtains, Duplicators, and Robotics.

Standard specifications for Gearhead

Reduction ratio	Gear stages	Allowable Torque		Moment maximum load		Allowable radial load N	Allowable axial load N
		mN·m	kgf·cm	mN·m	kgf·cm		
15~26	2	49	0.5	73.5	0.75	4.9	4.9
59~133	3	98	1.0	147.0	1.5	4.9	4.9

Characteristic for Geared Motor

Part No				TGU16—24S (24V type)						TGU16—12S (12V type)					
Reduction ratio	Gear stages	Direction	Weight g	No-load		Rating				No-load		Rating			
				Rev.	Current	Torque		Rev.	Current	Rev.	Current	Torque		Rev.	Current
				r/min	mA	mN·m	kgf·cm	r/min	mA	r/min	mA	mN·m	kgf·cm	r/min	mA
15	2	CCW	39	1,279	60	5.88	0.06	1,192	89.2	588	55	5.88	0.06	501	84
20				978	60	7.84	0.08	911	89.8	449	55	7.84	0.08	382	85
26				748	60	9.8	0.1	699	88.5	344	55	9.8	0.1	294	83
59	3		40	328	60	19.6	0.2	307	87.7	151	55	19.6	0.2	130	83
78				251	60	19.6	0.2	238	81.2	115	55	19.6	0.2	103	76
101				192	60	29.4	0.3	181	84.3	88.1	55	29.4	0.3	77.3	79
133		147		60	39.2	0.4	138	84.8	67.4	55	39.2	0.4	58.9	80	

Standard specifications for motor

Type No.	Voltage V	No-load		Rating				Starting			Weight g	Brush	Noise element	
		Rev.	Current	Output	Torque		Rev.	Current	Torque	Current				
		r/min	mA	W	mN·m	gf·cm	r/min	mA	mN·m	gf·cm				mA
TP-1621A-24	DC24	21,000	35	0.9	0.49	5.0	18,700	85	4.48	45.7	491.5	15	Carbon	Varistor
TP-1621A-12	DC12	10,500	25	0.4	0.29	5.0	8,200	75	2.24	22.8	253.3	15	Carbon	Varistor

TOK BEARING CO.,LTD.

HEAD OFFICE, TOKYO, JAPAN — TEL : 81-3-3969-1534 FAX : 81-3-3969-9354
EMAIL : overseas@tok-bearing.co.jp

Product specification are subject to change without prior notice.

Before assembly or use of any bearing, please read "Caution for Use"



Cautions for the Use of DC Geared Motors

- 1.** Be sure to use our product under ambient conditions in a temperature range from -10 to +50°C and a relative humidity range from 30 to 90%RH (no condensation).
The numerical values of all properties given in this catalogue are based on a temperature of 23°C and a relative humidity of 65%RH. Remember that using it in a high-humidity environment will cause problems such as corrosion of component parts and loss of product characteristics. Use the product with due caution.
- 2.** Store this product at temperatures from -20°C to +60°C and relative humidity from 10 to 95%RH (no condensation).
Remember that in the event that the product is kept in ambient conditions outside the guaranteed this will cause problems such as corrosion of component parts and loss of product characteristics. Use the product with due caution.
- 3.** Use screws of the length range stated in the catalogue when you install the DC geared motor. If you use screws that are longer than the range stated in the catalogue, they will make contact with the interior parts of the gear head, causing problems.
- 4.** Do not install the DC motor output shaft facing upwards. (Gear grease applied to the gear will gradually infiltrate inside the motor interior as time passes. If the infiltrated grease settles on the commutator of the motor it will mix with the friction powder of the motor brush and the mixture will enter the grooves in the commutator, causing a short-circuit between the coils.)
(If you do use the output shaft facing upwards we can provide means against oil ingress, so be sure to contact us.)
- 5.** If you continue to operate (energize) the motor at overload conditions, this causes problems in that motor performance will deteriorate and the insulation coating of the motor coils (copper wires) will melt and release smoke and burn out (layer short). Examples of how you can prevent are: (1) If you detect a current surge, use a time-lag fuse to interrupt the current. (2) You may use a current protection element with favorable recovery properties (posister or polyswitch). If you have detected an overload or locking condition of the machine or the electric motor you may use the method of switching the motor drive circuit OFF. Be sure to provide protection measures for the motor.
- 6.** Do not lock or apply an impact load to the output side of the gear head during operation. Caution is required, as this would cause serious difficulty due to the gear teeth breaking.
- 7.** Caution is required in case of continuous operation with a gear head structure designed for intermittent operation, as in this case the slide faces of the inner diameter of the gear and the shaft column would develop heat due to friction and may result in a burnout.
- 8.** Many DC brush motors use carbon brushes. Beware that when you operate the motor at low speed using, for example, a low voltage or PWM control (the speed you should aim at should be 2,500 rpm or less for the motor alone) the friction powder of the brush will settle in the commutator grooves and cause a short-circuit between the windings. (This will not only lead to the motor developing smoke and burning damage (layer short) but may also lead to a burnout of the motor driver.)
- 9.** When the motor suddenly reverses during DC gear motor operation or while it rotates due to inertia after switching OFF the power supply, electricity is generated (back flow). The start current + the generation of electricity will result in a large current flowing. As this can cause serious problems, including the development of smoke and burning damage of the motor drive circuit and the motor, be sure not to always reverse the motor's sense of rotation until after you have stopped the motor.
- 10.** When you use PWM control, pay attention to the details of item 8 and to the frequency range that is used. As a result of the phase properties of each motor and motor drive circuits and of the noise element (Varister, electrolytic capacitor) that is built into the motor, troubles such as resonance (abnormal noise), heat evolution, and motor stop may occur depending on the frequency range. Be sure therefore to check the optimum frequency range for each motor.
- 11.** Beware that the amount of overrun of each motor unit will vary depending on the ambient conditions and the characteristics of each motor. Beware that restraining (locking) the output shaft forcibly from outside while the motor is in inertial motion after switching the motor OFF or causing the overrun motion to decelerate by instantaneous reversal of direction of rotation will lead to breakdown.
- 12.** Beware that the noise of our DC brush motor can have an adverse effect on the peripheral circuits.
- 13.** In the event that additional work is performed after delivery of our product be sure to remember that such work will be outside the scope of warranty.
- 14.** If you add gears or a pulley to the output shaft of the DC geared motor, be sure to take the following details fully into consideration.
If you mount by pressure fit do not apply a load in excess of the maximum allowable load in the thrust direction of the output shaft.
In case of installation using an adhesive, make sure that the adhesive will not adhere to, or accumulate on, the sliding surface of the inner diameter of the output shaft bearing metal and the outer circumference of the output shaft. Furthermore, beware that the use of volatile adhesives will lead to the formation of hazardous gases.
- 15.** Be sure to pay proper attention to overtensioning the belt when you use the drive source (gear, pulley, etc.) you have attached to the output shaft of the DC geared motor. Remember that the application of a thrust or radial load in excess of the maximum allowable load will cause problems.
- 16.** Be sure to pay proper attention to ensure that when you solder leads and ceramic capacitors to the input terminals of the DC geared motor, the tip of the soldering iron does not have an excessively high temperature and the work time during which the soldering iron makes contact is not too long.
- 17.** Be sure to remember that dropping the DC geared motor and applying impact from outside will result in problems including damage of parts and the gears coming out of mesh. Also beware that applying impact to the input terminal will result in problems such as poor electrical contact due to stress acting on the connection between the motor terminal and the interior of the motor.
- 18.** The DC geared motor is operated letting it rotate from the motor side. Be sure not to let it rotate from the output shaft side. Beware that this would damage the gear.

* When using, be sure to pay proper attention to the above details. If you have any uncertainty or query please do not hesitate to contact our sales representative in charge.

TOK BEARING CO., LTD.

BEARINGS



Plastic bearings with a multitude configurations and materials that can suit any customer demand

BEARING PART NUMBER NOMENCLATURE AND DESCRIPTIONS

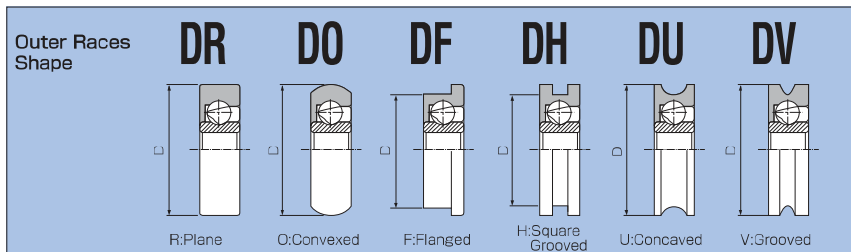

Index number of outer races diameter

In most cases, this number reflects the overall diameter of the bearings. Exceptions are: DH-type of bearing with square groove—index number reflects the "bottom-to-bottom" diameter; DF—type with flanged shape—index number reflects each diameter of the race threads.

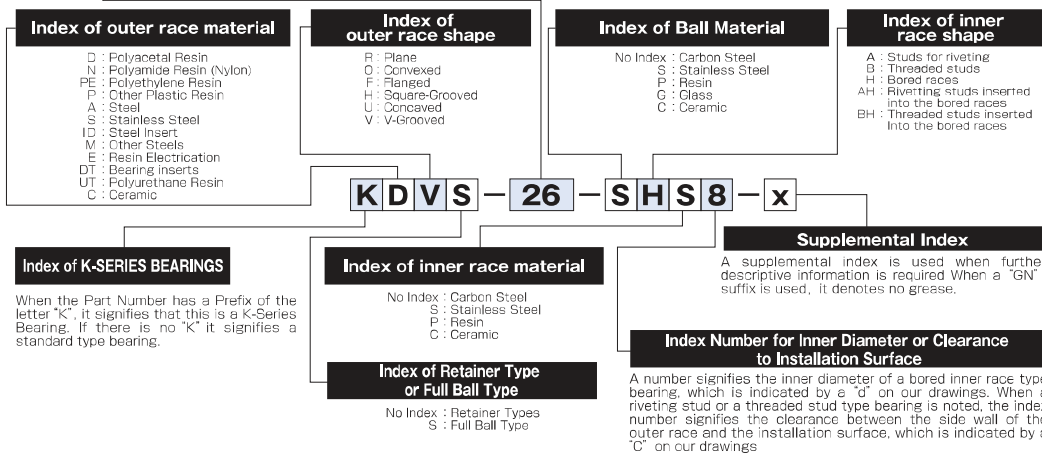

K D V S - 26 - S H S 8 - X



[Bearings]

1. Operation temperature : 0°C~40°C (Special designing for use -20°C~60°C is also available)
2. Load capacity indicated in the brochure is based on 1,000,000 revolution test with TOK BEARING durability testing machine.
3. Do not use bearings under axial load.



D-SERIES BEARINGS

DR-A

DR-A

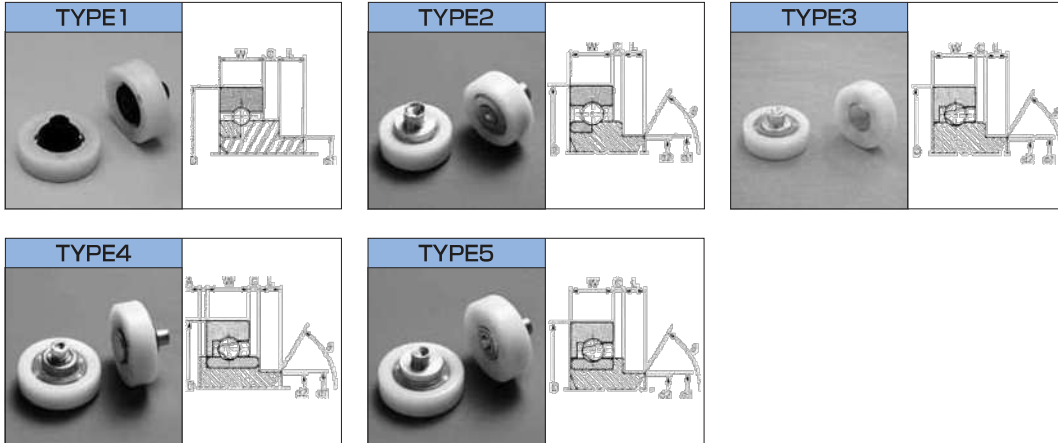

Code	Part No.	D _{-0.1} [mm]	d1 _{-0.1} [mm]	W _{-0.2} [mm]	C ^{±0.4} [mm]	L ^{±0.2} [mm]	(d2 × θ) ^{*1}	A ^{±0.2} [mm]	Load ^{*2} [N] (kgf)	Type	Q'ty [pcs/box]	Gross Weight [kg/box]
000006	DRS-9-A0.5	9 _{-0.05}	2 _{-0.05}	3 _{-0.1}	0.5	1.8	—	—	[9.8] (1)	1	10,000	—
000007	DRS-12-A0.5	12 _{-0.05}	3 _{-0.05}	4 ^{±0.1}	0.5 ^{±0.3}	2.3	—	—	[9.8] (1)	1	10,000	—
000001	DRS-16-A1	16 _{-0.3}	4	5 ^{±0.2}	1	3.5	φ3 × 100°	—	19.6 (2)	2	2,000	9.0
000003	DRS-16-A1.5	16 _{-0.3}	5	6.35 ^{±0.2}	1.5	3.5	φ4.5 × 90°	—	19.6 (2)	2	2,500	14.4
000100	DR-18-A0.5	18	5	6	0.5	3.5	φ4 × 120°	—	19.6 (2)	3	2,000	9.6
000200	DR-19-A0.5	19	5	6	0.5	3.5	φ4 × 120°	—	29.4 (3)	3	2,000	10.7
000207	DR-19-A2	19	5	6	2	3.5	φ4.4 × 120°	—	29.4 (3)	3	2,000	11.6
000408	DR-22-A-2.1	22	5	7	0	2.1	φ4 × 90°	—	78.4 (8)	3	1,000	7.4
000400	DR-22-A1	22	5	7	1	3.5	φ4.4 × 90°	—	78.4 (8)	3	1,000	9.0
000410	DR-22-A2-φ6	22	6	7	2	3.5	φ5.5 × 90°	—	78.4 (8)	3	1,000	9.4
000411	DR-22-A2	22	5	7	2	3.5	φ4 × 90°	—	78.4 (8)	3	1,000	8.9
000600	DR-24-A1	24	5	7	1	3.5	φ4.4 × 90°	—	78.4 (8)	3	1,000	9.5
000700	DR-26-A1	26	5	7	1	3.5	φ4.4 × 90°	—	78.4 (8)	3	1,000	10.2
000800	DR-28-A1	28	5	7	1	3.5	φ4.4 × 90°	—	78.4 (8)	3	500	5.8
000900	DR-29-A1	29	5	7	1	3.5	φ4.4 × 90°	—	78.4 (8)	3	500	5.7
000427	DR-22-AH (1) 3.5-8019	22	4.5 ^{±0.1}	7	0	3.5 ^{+0.3}	nothing	1	196 (20)	4	1,000	9.1
000419	DR-22-AH2.5-3.65	22	4.5 ^{±0.1}	7	2.5	3.65	φ2.5 × 100°	1	196 (20)	4	1,000	10.2
000705	DR-26-AH	26	4.5 ^{±0.1}	7	0	3.5 ^{+0.3}	nothing	1 ^{±0.3}	196 (20)	4	1,000	10.2
000707	DR-26-AH2.5-3.65	26	4.5 ^{±0.1}	7	2.5	3.65	φ2.5 × 100°	1	196 (20)	4	800	8.8
040707	DR-26-AH2.7-2.7	26	3.9 _{-0.2}	7	2.7	2.7	φ2.3 × 110°	1 ^{±0.3}	196 (20)	4	800	8.8
040706	DR-26-AH2.7-4	26	3.9 _{-0.2}	7	2.7	4 ^{±0.3}	φ2.7 × 120°	1 ^{±0.3}	196 (20)	4	800	9.8
000414	DR-22-AH2.5	22	5	7	2.5	3.5	φ4 × 110°	—	196 (20)	5	1,000	10.0
000416	DR-22-AH3.8-2.5	22	4.9	7	3.8	2.5	nothing	—	196 (20)	5	1,000	10.6
000417	DR-22-AH4	22	5	7	4	3.5	φ4 × 110°	—	196 (20)	5	1,000	10.8
000706	DR-26-AH4	26	5	7	4	3.5	φ4 × 110°	—	196 (20)	5	800	9.8

*1 Reference Dimension

*2 Allowable Load at 300min⁻¹ (300r.p.m.)

Size limits can be modified for practical applications. Please contact our sales/engineering departments for further information and assistance.

TOK BEARING CO.,LTD.

HEAD OFFICE, TOKYO, JAPAN – TEL : 81-3-3969-1534 FAX : 81-3-3969-9354
EMAIL : overseas@tok-bearing.co.jp

Product specification are subject to change without prior notice.

Before assembly or use of any bearing, please read "Caution for Use"

D-SERIES BEARINGS

DR-B

DR-B

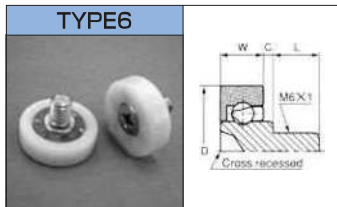

Code	Part No.	D _{-0.1} [mm]	W _{-0.2} [mm]	C ^{±0.4} [mm]	L ^{±0.5} [mm]	Load ^{*1} [N] (kgf)	Type	Q'ty [pcs/box]	Gross Weight [kg/box]
020200	DR-19-B0.5	19	6	0.5	8	49 (5)	6	2,000	12.5
020207	DR-19-B1-14	19	6	1	14	49 (5)	6	1,500	11.1
020208	DR-19-B1.5	19	6	1.5	8	49 (5)	6	2,000	12.9
020212	DR-19-B3.5	19	6	3.5	8	49 (5)	6	1,500	11.0
020404	DR-22-B0.5-4.5	22	7	0.5	4.5	196 (20)	6	1,000	8.4
020400	DR-22-B0.5	22	7	0.5	8	196 (20)	6	1,000	9.8
020408	DR-22-B1-10	22	7	1	10	196 (20)	6	1,000	9.5
020428	DR-22-B3-10.5	22	7	3	10.5	196 (20)	6	1,000	11.5
020427	DR-22-B3.6-12.4	22	7	3.6	12.4	196 (20)	6	1,000	10.9
020415	DR-22-B3.6-14.5	22	7	3.6	14.5	196 (20)	6	1,000	11.9
020600	DR-24-B0.5	24	7	0.5	8	196 (20)	6	1,000	10.4
020608	DR-24-B3-10.5	24	7	3	10.5	196 (20)	6	1,000	11.7
020702	DR-26-B0.5-4.5	26	7	0.5	4.5	196 (20)	6	1,000	9.7
020700	DR-26-B0.5	26	7	0.5	8	196 (20)	6	1,000	10.1
020720	DR-26-B3-10.5	26	7	3	10.5	196 (20)	6	800	10.7
020719	DR-26-B3.6-12.4	26	7	3.6	12.4	196 (20)	6	800	11.3
020714	DR-26-B5-11	26	7	5	11	196 (20)	6	800	8.8
020800	DR-28-B0.5	28	7	0.5	8	196 (20)	6	500	6.7
020803	DR-28-B2-15	28	7	2	15	196 (20)	6	500	6.7
020805	DR-28-B3-10.5	28	7	3	10.5	196 (20)	6	500	6.9
021000	DR-30-B0.5	30	7	0.5	8	196 (20)	6	500	6.8
021005	DR-30-B3-10.5	30	7	3	10.5	196 (20)	6	500	7.6
021004	DR-30-B3.6-12.4	30	7	3.6	12.4	196 (20)	6	500	12.5

*1 Allowable Load at 300min⁻¹ (300r.p.m.)

Size limits can be modified for practical applications. Please contact our sales/engineering departments for further information and assistance.

D-SERIES BEARINGS

DR-B

DR-B

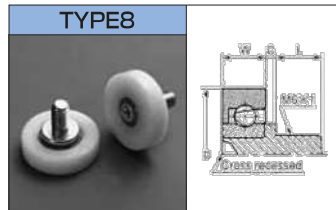
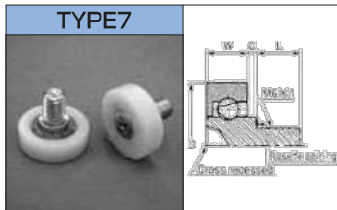

Code	Part No.	D _{-0.1} [mm]	W _{-0.2} [mm]	C ^{±0.4} [mm]	L ^{±0.5} [mm]	Load ^{*1} [N] (kgf)	Type	Q'ty [pcs/box]	Gross Weight [kg/box]
020205	DR-19-B1-5.5	19	6	1	5.5	49 (5)	7	2,000	11.5
020204	DR-19-B1	19	6	1	8	49 (5)	7	2,000	13.5
020210	DR-19-B2-4.5	19	6	2	4.5	49 (5)	7	2,000	12.1
020209	DR-19-B2	19	6	2	8	49 (5)	7	2,000	14.0
020211	DR-19-B2.7	19	6	2.7	8	49 (5)	7	1,500	10.2
020214	DR-19-B3	19	6	3	8	49 (5)	7	1,500	10.7
020406	DR-22-B1	22	7	1	8	196 (20)	7	1,000	9.0
020411	DR-22-B2-5.5	22	7	2	5.5	196 (20)	7	1,000	9.3
020409	DR-22-B2	22	7	2	8	196 (20)	7	1,000	10.3
020413	DR-22-B3	22	7	3	8	196 (20)	7	1,000	11.3
020418	DR-22-B4-4.5	22	7	4	4.5	196 (20)	7	1,000	10.3
020416	DR-22-B4	22	7	4	8	196 (20)	7	1,000	11.7
020420	DR-22-B5	22	7	5	8	196 (20)	7	1,000	12.3
020422	DR-22-B6	22	7	6	8	196 (20)	7	1,000	12.8
020602	DR-24-B2	24	7	2	8	196 (20)	7	1,000	11.4
020604	DR-24-B3	24	7	3	8	196 (20)	7	1,000	11.7
020605	DR-24-B4	24	7	4	8	196 (20)	7	1,000	12.4
020606	DR-24-B5	24	7	5	8	196 (20)	7	1,000	12.5
020607	DR-24-B6	24	7	6	8	196 (20)	7	1,000	13.3
020705	DR-26-B2	26	7	2	8	196 (20)	7	800	9.2
020707	DR-26-B3	26	7	3	8	196 (20)	7	800	9.7
020710	DR-26-B4	26	7	4	8	196 (20)	7	800	10.1
020716	DR-26-B6-6	26	7	6	6	196 (20)	7	800	10.7
020715	DR-26-B6	26	7	6	8	196 (20)	7	800	11.1
020801	DR-28-B2	28	7	2	8	196 (20)	7	500	6.7
021002	DR-30-B3	30	7	3	8	196 (20)	7	500	11.3
020429	DR-22-BH2-11	22	7	2	11	196 (20)	8	1,000	12.3
020430	DR-22-BH3-11	22	7	3	11	196 (20)	8	1,000	11.4
020722	DR-26-BH2-11	26	7	2	11	196 (20)	8	800	10.6
020804	DR-28-BH2-11	28	7	2	11	196 (20)	8	500	6.9

*1 Allowable Load at 300min⁻¹ (300r.p.m.)

Size limits can be modified for practical applications. Please contact our sales/engineering departments for further information and assistance.

TOK BEARING CO.,LTD.

HEAD OFFICE, TOKYO, JAPAN – TEL : 81-3-3969-1534 FAX : 81-3-3969-9354
EMAIL : overseas@tok-bearing.co.jp

Product specification are subject to change without prior notice.

Before assembly or use of any bearing, please read "Caution for Use"

D-SERIES BEARINGS

DR-H

DR-H

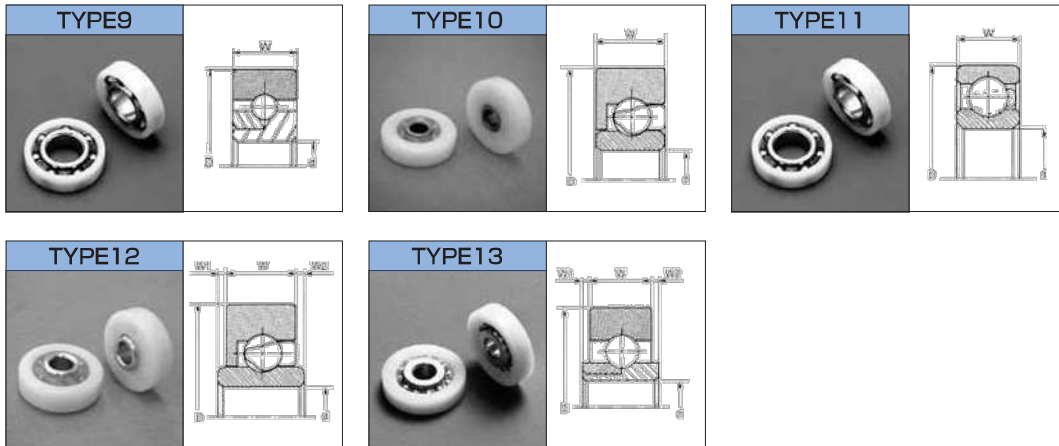

Code	Part No.	D _{-0.1} [mm]	d ^{+0.1} [mm]	W _{-0.2} [mm]	W1*1 [mm]	W2*1 [mm]	Load*2 [N] (kgf)	Type	Q'ty [pcs/box]	Gross Weight [kg/box]
040012	DRS-9-H2.5	9 _{-0.05}	2.5 ^{+0.05}	3 ^{±0.1}	—	—	9.8 (1)	9	10,000	—
040013	DRS-12-H3	12 _{-0.05}	3 ^{+0.05}	4 ^{±0.1}	—	—	9.8 (1)	9	10,000	—
040100	DR-18-H6	18	6	6	—	—	49 (5)	10	2,500	7.6
040202	DR-19-H5	19	5	6	—	—	49 (5)	10	2,500	8.9
040205	DR-19-H6	19	6	6	—	—	49 (5)	10	2,500	8.1
040301	DR-20-H8	20	8	6 ^{±0.1}	—	—	29.4 (3)	10	1,500	6.1
040401	DR-22-H6	22	6	7	—	—	196 (20)	10	1,500	9.5
040412	DR-22-H8	22	8	7	—	—	49 (5)	10	1,500	8.2
040600	DR-24-H6	24	6	7	—	—	196 (20)	10	1,000	7.1
040602	DR-24-H10.5	24	10.5	7	—	—	49 (5)	10	1,000	11.5
040701	DR-26-H6	26	6	7	—	—	196 (20)	10	1,000	7.8
041600	DR-26-H10	26	10	8	—	—	196 (20)	10	1,000	7.9
040800	DR-28-H6	28	6	7	—	—	196 (20)	10	500	4.2
041000	DR-30-H6	30	6	7	—	—	196 (20)	10	500	5.6
041610	DR-30-H10-9	30	10	9	—	—	245 (25)	10	500	7.7
041005	DR-30-H10-8	30	10	8 ^{±0.1}	—	—	245 (25)	10	500	6.7
041612	DR-32-H12	32	12	10	—	—	294 (30)	10	500	9.6
041100	DR-35-H6	35	6	7	—	—	196 (20)	10	500	5.7
041614	DR-35-H15	35	15	11 ^{±0.2}	—	—	294 (30)	10	400	10.6
041151	DR-38-H10	38	10	8 ^{±0.2}	—	—	196 (20)	10	500	6.1
041200	DR-40-H6	40 _{-0.2}	6	8	—	—	196 (20)	10	400	5.4
041616	DR-40-H17	40	17	12 ^{±0.2}	—	—	294 (30)	10	250	6.9
041618	DR-47-H20	47	20	14	—	—	343 (35)	10	150	8.7
040102	DR-18-H8	18	8	5	—	—	49 (5)	11	3,000	8.7
040007	DR-16-H4.1W0.25	16	4.1	4	0.25	0.25	19.6 (2)	12	4,000	9.6
040200	DR-19-H4W (1.3) 3	19	4	6	1.3	3	49 (5)	12	1,500	8.2
040204	DR-19-H5W (0) 2.3	19	5	6	0	2.3	49 (5)	12	2,000	8.6
040400	DR-22-H4W (0.5) 3	22	4	7	0.5	3	196 (20)	12	1,000	8.3
040415	DR-22-H6W1	22	6	7	1	1	196 (20)	12	1,000	6.6
040601	DR-24-H6W1	24	6	7	1	1	196 (20)	12	1,000	7.3
040700	DR-26-H4W (0.5) 3	26	4	7	0.5	3	196 (20)	12	1,000	9.7
040704	DR-26-H6W1	26	6	7	1	1	196 (20)	12	1,000	8.8
040802	DR-28-H6W1	28	6	7	1	1	196 (20)	12	500	4.5
041003	DR-30-H6W1	30	6	7	1	1	196 (20)	12	500	6.4
041101	DR-35-H6W1	35	6	7	1	1	196 (20)	12	500	6.8
041201	DR-40-H6W0.5	40 _{-0.2}	6	8	0.5	0.5	196 (20)	12	400	5.5
041300	DR-47-H8W (0) 9	47	8	14	0	9	196 (20)	12	100	3.5
040005	DRS-16-H4.1W0.25	16	4.1	3.5 ^{±0.2}	0.25	0.25	49 (5)	13	5,000	11.0

*1 Reference Dimension *2 Allowable Load at 300min -1 (300r.p.m.)

Size limits can be modified for practical applications. Please contact our sales/engineering departments for further information and assistance.

TOK BEARING CO.,LTD.

HEAD OFFICE, TOKYO, JAPAN – TEL : 81-3-3969-1534 FAX : 81-3-3969-9354
EMAIL : overseas@tok-bearing.co.jp

Product specification are subject to change without prior notice.

Before assembly or use of any bearing, please read "Caution for Use"

D-SERIES BEARINGS

DO

DO

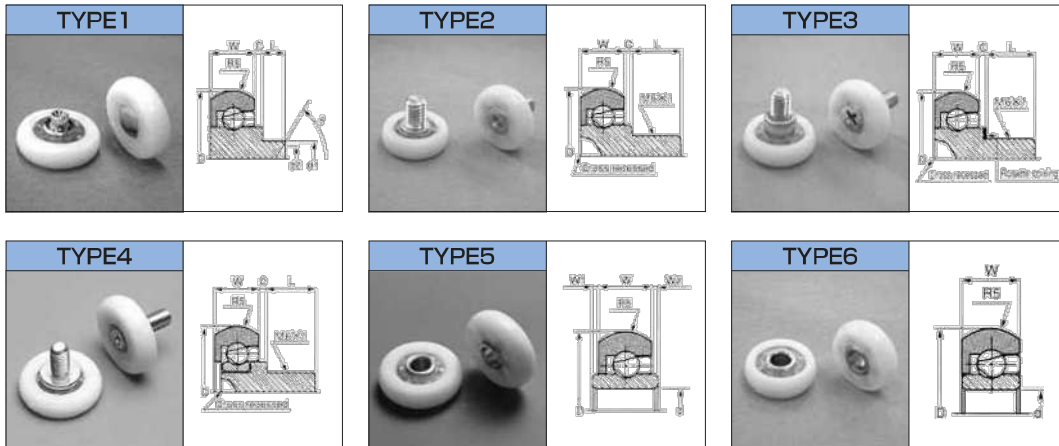

Code	Part No.	D _{-0.2} [mm]	d ^{+0.1} [mm]	d1 _{-0.1} [mm]	W _{-0.2} [mm]	C ^{±0.4} [mm]	L ^{±0.2} [mm]	(d2×θ) ^{*1}	W1 ^{*1} [mm]	W2 ^{*1} [mm]	Load ^{*2} [N] (kgf)	Type	Q'ty [pcs/box]	Gross Weight [kg/box]
070010	DO-19-A0.5	19	—	5	6	0.5	3.5	φ4 ×120°	—	—	29.4 (3)	1	2,000	10.8
070020	DO-22-A1	22	—	5	7	1	3.5	φ4.4× 90°	—	—	78.4 (8)	1	1,000	8.9
070021	DO-22-A3	22	—	5	7	3	3.5	φ4 × 90°	—	—	78.4 (8)	1	1,000	9.3
070030	DO-24-A1	24	—	5	7	1	3.5	φ4.4× 90°	—	—	78.4 (8)	1	1,000	9.8
070040	DO-26-A1	26	—	5	7	1	3.5	φ4.4× 90°	—	—	78.4 (8)	1	1,000	10.3
071010	DO-19-B0.5	19	—	—	6	0.5	8 ^{±0.5}	—	—	—	49 (5)	2	2,000	12.5
071012	DO-19-B0.5-4.5	19	—	—	6	0.5	4.5 ^{±0.5}	—	—	—	49 (5)	2	2,000	10.3
071020	DO-22-B0.5	22	—	—	7	0.5	8 ^{±0.5}	—	—	—	196 (20)	2	1,000	9.3
071026	DO-22-B3-10.5	22	—	—	7	3	10.5 ^{±0.5}	—	—	—	196 (20)	2	1,000	10.4
071030	DO-24-B0.5	24	—	—	7	0.5	8 ^{±0.5}	—	—	—	196 (20)	2	1,000	10.3
071040	DO-26-B0.5	26	—	—	7	0.5	8 ^{±0.5}	—	—	—	196 (20)	2	1,000	10.7
071050	DO-28-B0.5	28	—	—	7	0.5	8 ^{±0.5}	—	—	—	196 (20)	2	500	6.3
071023	DO-22-B5	22	—	—	7	5	8 ^{±0.5}	—	—	—	196 (20)	3	1,000	11.2
071031	DO-24-B2	24	—	—	7	2	8 ^{±0.5}	—	—	—	196 (20)	3	1,000	10.8
071032	DO-24-B3	24	—	—	7	3	8 ^{±0.5}	—	—	—	196 (20)	3	1,000	11.8
071034	DO-24-B4	24	—	—	7	4	8 ^{±0.5}	—	—	—	196 (20)	3	1,000	11.6
071060	DO-30-B3	30	—	—	7	3	8 ^{±0.5}	—	—	—	196 (20)	3	500	6.4
071035	DO-24-BH0.5	24	—	—	7	0.5	8 ^{±0.5}	—	—	—	196 (20)	4	1,000	8.8
071045	DO-26-BH2-11	26	—	—	7	2	11 ^{±0.5}	—	—	—	196 (20)	4	800	10.1
072031	DO-24-H6W1	24	6	—	7	—	—	—	1	1	196 (20)	5	1,000	7.8
072043	DO-26-H6W1	26	6	—	7	—	—	—	1	1	196 (20)	5	1,000	8.5
072072	DO-35-H6W1	35	6	—	7	—	—	—	1	1	196 (20)	5	500	5.1
072080	DO-40-H6W0.5	40	6	—	8 _{-0.3}	—	—	—	0.5	0.5	196 (20)	5	400	4.5
072000	DO-18-H5	18	5	—	6	—	—	—	—	—	49 (5)	6	2,500	8.1
072010	DO-19-H5	19	5	—	6	—	—	—	—	—	49 (5)	6	2,500	9.8
072020	DO-22-H6	22	6	—	7	—	—	—	—	—	196 (20)	6	1,500	8.9
072030	DO-24-H6	24	6	—	7	—	—	—	—	—	196 (20)	6	1,000	7.3
072040	DO-26-H6	26	6	—	7	—	—	—	—	—	196 (20)	6	1,000	8.0
072050	DO-28-H6	28	6	—	7	—	—	—	—	—	196 (20)	6	800	8.7
072060	DO-29-H6	29	6	—	7 _{-0.1}	—	—	—	—	—	196 (20)	6	500	4.0

*1 Reference Dimension *2 Allowable Load at 300min -1 (300r.p.m.)
 Size limits can be modified for practical applications. Please contact our sales/engineering departments for further information and assistance.

TOK BEARING CO.,LTD.

HEAD OFFICE, TOKYO, JAPAN – TEL : 81-3-3969-1534 FAX : 81-3-3969-9354
 EMAIL : oversea@tok-bearing.co.jp

Product specification are subject to change without prior notice.
Before assembly or use of any bearing, please read "Caution for Use"

D-SERIES BEARINGS

DU

DU

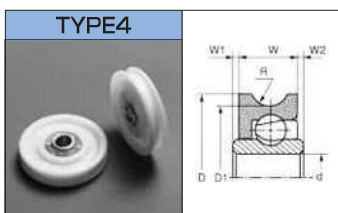
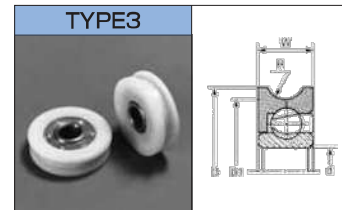
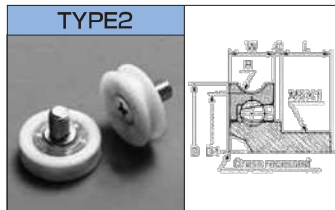
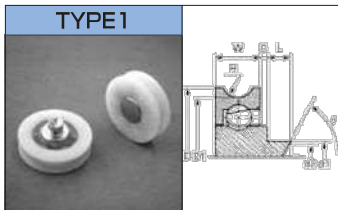

Code	Part No.	D ^{+0.2} [mm]	D1 ^{+0.1} [mm]	d ^{+0.1} ₀ [mm]	d1 ^{-0.1} [mm]	W ^{-0.2} [mm]	C ^{±0.4} [mm]	L ^{+0.2} [mm]	*1 (d2 × θ)	W1 ^{*1} [mm]	W2 ^{*1} [mm]	R	Load ^{*2} [N] (kgf)	Type	Q'ty [pcs/box]	Gross Weight [kg/box]
080010	DU-19-A0.5	19	17	—	5	6	0.5	3.5	φ4 × 120°	—	—	1.75	29.4 (3)	1	2,000	10.3
080020	DU-22-A1	22	19.2	—	5	7	1	3.5	φ4.4 × 90°	—	—	2.5	58.8 (6)	1	1,000	8.5
080030	DU-24-A1	24	21.2	—	5	7	1	3.5	φ4.4 × 90°	—	—	2.5	58.8 (6)	1	1,000	9.3
080040	DU-26-A1	26	23.2	—	5	7	1	3.5	φ4.4 × 90°	—	—	2.5	58.8 (6)	1	1,000	10.3
081010	DU-19-B0.5	19	17	—	—	6	0.5	8 ^{±0.5}	—	—	—	1.75	39.2 (4)	2	2,000	12.4
081013	DU-19-B2	19	17	—	—	6	2	8 ^{±0.5}	—	—	—	1.75	39.2 (4)	2	2,000	12.8
081020	DU-22-B0.5	22	19.2	—	—	7	0.5	8 ^{±0.5}	—	—	—	2.5	156 (16)	2	1,000	9.8
081021	DU-22-B6	22	19.2	—	—	7	6	8 ^{±0.5}	—	—	—	2.5	156 (16)	2	1,000	11.8
081030	DU-24-B0.5	24	21.2	—	—	7	0.5	8 ^{±0.5}	—	—	—	2.5	156 (16)	2	1,000	10.5
081040	DU-26-B0.5	26	23.2	—	—	7	0.5	8 ^{±0.5}	—	—	—	2.5	156 (16)	2	1,000	11.3
082010	DU-19-H5	19	17	5	—	6	—	—	—	—	—	1.75	39.2 (4)	3	2,500	9.8
082020	DU-22-H6	22	19.2	6	—	7	—	—	—	—	—	2.5	156 (16)	3	1,500	8.8
082060	DU-24-H6	24	21.2	6	—	7	—	—	—	—	—	2.5	156 (16)	3	1,000	6.7
082070	DU-26-H6	26	23.2	6	—	7	—	—	—	—	—	2.5	156 (16)	3	1,000	7.4
082100	DU-30-H6-M	30	25.7	6	—	7 ^{+0.2}	—	—	—	—	—	2.5	156 (16)	3	500	3.6
082101	DU-30-H10	30	26	10	—	8 ^{+0.2}	—	—	—	—	—	2.5	196 (20)	3	500	6.1
082031	DU-22-H6W0.5	22	19	6	—	7	—	—	—	0.5	0.5	2.5	156 (16)	4	1,500	5.8
082028	DU-22-H6W1	22	19.2	6	—	7	—	—	—	1	1	2.5	156 (16)	4	1,000	6.2
082090	DU-28-H6W1	28	24	6	—	7	—	—	—	1	1	2.5	156 (16)	4	800	8.0
082103	DU-30-H6W1	30	25.7	6	—	7	—	—	—	1	1	2.5	156 (16)	4	500	6.1
082110	DU-35-H6W1	35	31	6	—	7	—	—	—	1	1	2.5	156 (16)	4	500	5.8
082120	DU-40-H6W0.5	40	36	6	—	8 ^{+0.2}	—	—	—	0.5	0.5	2.5	156 (16)	4	400	5.4

*1 Reference Dimension

*2 Allowable Load at 300min -1 (300r.p.m.)

Size limits can be modified for practical applications. Please contact our sales/engineering departments for further information and assistance.

TOK BEARING CO.,LTD.

HEAD OFFICE, TOKYO, JAPAN – TEL : 81-3-3969-1534 FAX : 81-3-3969-9354
EMAIL : overseas@tok-bearing.co.jp

Product specification are subject to change without prior notice.

Before assembly or use of any bearing, please read "Caution for Use"

D-SERIES BEARINGS

DV

DV

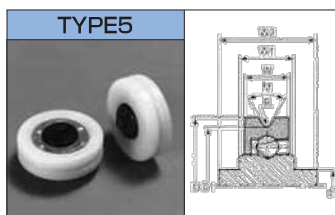
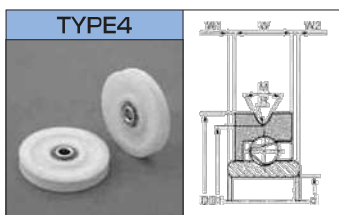
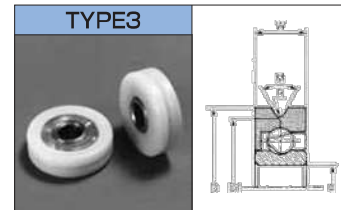
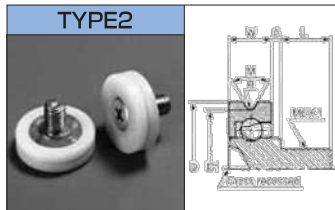
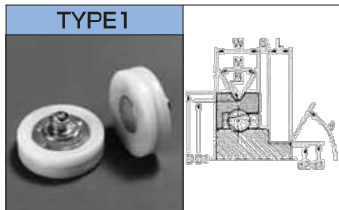

Code	Part No.	D ^{+0.2} [mm]	D1 ^{+0.2} [mm]	d ^{+0.1} [mm]	d1 ₀ [mm]	W ₀ [mm]	C ^{+0.4} [mm]	L ^{+0.2} [mm]	*1 (d2 × θ)	W1 ^{*1} [mm]	W2 ^{*1} [mm]	M*	R	Type	Q'ty [pcs/box]	Gross Weight [kg/box]
090000	DV-19-A0.5	19	17	—	5	6	0.5	3.5	φ4 × 120°	—	—	60	0.6	1	2,000	11.0
090100	DV-22-A1	22	19	—	5	7	1	3.5	φ4.4 × 90°	—	—	60	0.6	1	1,000	9.2
090200	DV-24-A1	24	21	—	5	7	1	3.5	φ4.4 × 90°	—	—	60	0.6	1	1,000	9.8
090300	DV-26-A1	26	23	—	5	7	1	3.5	φ4.4 × 90°	—	—	60	0.6	1	1,000	10.6
090400	DV-28-A1	28	24	—	5	7	1	3.5	φ4.4 × 90°	—	—	(58)	0.6	1	500	5.3
090500	DV-30-A1	30	27	—	5	7	1	3.5	φ4.4 × 90°	—	—	60	0.6	1	500	6.5
090600	DV-38-A0.5	38	35	—	5	8 ^{+0.2}	0.5	3.5	φ4.4 × 90°	—	—	60	0.6	1	500	7.5
091000	DV-19-B0.5	19	17	—	—	6	0.5	8 ^{+0.5}	—	—	—	60	0.6	2	2,000	12.6
091100	DV-22-B0.5	22	19	—	—	7	0.5	8 ^{+0.5}	—	—	—	60	0.6	2	1,000	10.0
091200	DV-24-B0.5	24	21	—	—	7	0.5	8 ^{+0.5}	—	—	—	60	0.6	2	1,000	10.6
091201	DV-24-B3	24	21	—	—	7	3	8 ^{+0.5}	—	—	—	60	0.6	2	1,000	10.7
091300	DV-26-B0.5	26	23	—	—	7	0.5	8 ^{+0.5}	—	—	—	60	0.6	2	1,000	11.2
091500	DV-30-B0.5-0.5R	30	28	—	—	7	0.5	8 ^{+0.5}	—	—	—	90	0.5	2	500	8.0
091501	DV-32.5-B1.5-2R	32.5	20.5	—	—	9.5 ^{+0.2}	1.5	8 ^{+0.5}	—	—	—	15	2	2	400	6.6
091600	DV-38-B0.5	38	35	—	—	8 ^{+0.2}	0.5	8 ^{+0.5}	—	—	—	60	0.6	2	250	5.8
092001	DV-19-H5	19	17	5	—	6	—	—	—	—	—	60	0.6	3	2,500	10.0
092100	DV-22-H6-M	22	19	6	—	7	—	—	—	—	—	60	0.6	3	1,500	9.7
092200	DV-24-H6	24	21	6	—	7	—	—	—	—	—	60	0.6	3	1,000	7.4
092201	DV-24-H8	24	20 ^{±1}	8	—	7	—	—	—	—	—	30	0.6	3	1,000	5.6
092300	DV-26-H6	26	23	6	—	7	—	—	—	—	—	60	0.6	3	1,000	8.0
092500	DV-30-H6	30	27	6	—	7	—	—	—	—	—	60	0.6	3	500	6.8
092700	DV-48-H6W0.4-1.6R	48.3	35	6	—	8.2 ^{+0.2}	—	—	—	0.4	0.4	30	1.6	4	250	4.1
090102	DV-22-AW0.5-B	22 ₀ ^{-0.1}	19 ^{±0.1}	—	3	7	—	—	—	8	12	60	0.65	5	1,000	8.9

***1 Reference Dimension**

Size limits can be modified for practical applications. Please contact our sales/engineering departments for further information and assistance. These products are made to order.

TOK BEARING CO.,LTD.

HEAD OFFICE, TOKYO, JAPAN – TEL : 81-3-3969-1534 FAX : 81-3-3969-9354
EMAIL : overseas@tok-bearing.co.jp

Product specification are subject to change without prior notice.

Before assembly or use of any bearing, please read "Caution for Use"

D-SERIES BEARINGS

DF/DH

DF

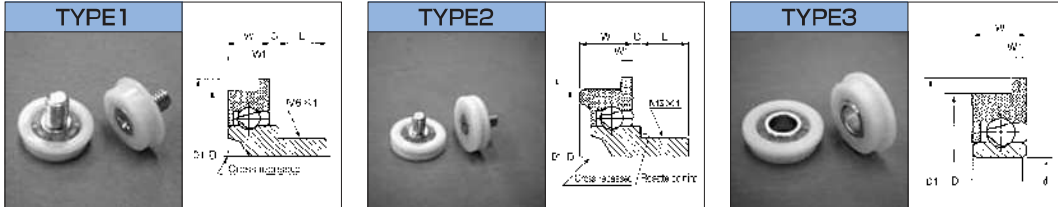

Code	Part No.	D _{-0.1} [mm]	D1 ^{±0.2} [mm]	d ^{+0.1} ₀ [mm]	W _{-0.2} [mm]	W1 ^{±0.2} [mm]	C ^{±0.4} [mm]	L ^{±0.5} [mm]	Load *1 [N] (kgf)	Load *2 [N] (kgf)	Type	Q'ty [pcs/box]	Gross Weight [kg/box]
061001	DF-17-B0.5	17	19	—	6	1	0.5	8	49 (5)	—	1	1,500	10.0
061020	DF-22-B0.5	22	26	—	7	2	0.5	8	196 (20)	—	1	1,000	9.4
061040	DF-26-B1	26 ^{±0.2}	32	—	11 ^{±0.2}	3	1	8	196 (20)	—	2	400	5.3
061043	DF-26-B2	26 ^{±0.2}	32	—	11 ^{±0.2}	3	2	8	196 (20)	—	2	400	5.8
062000	DF-17-H6	17	19 ^{±0.1}	6	6	1 ^{±0.1}	—	—	49 (5)	14.7 (1.5)	3	3,000	9.5
062005	DF-19-H6	19	22	6	7	1.5	—	—	147 (15)	29.4 (3)	3	1,500	7.7
062020	DF-22-H6	22	26	6	7	2	—	—	196 (20)	39.2 (4)	3	1,500	9.5
062027	DF-23-H10	23	24.75	10	8 ^{±0.2}	1.5 ^{±0.1}	—	—	98 (10)	39.2 (4)	3	1,000	7.2
062061	DF-30-H10-3	30	34	10	8.5 ^{±0.2}	3	—	—	245 (25)	58.8 (6)	3	500	7.0
062062	DF-32-H12	32	36	12	10	3	—	—	245 (25)	58.8 (6)	3	400	7.5

*1 Allowable Load at 300rpm -1 rotation of outer-race

*2 Allowable Load at 300rpm -1 rotation of inner-race

Size limits can be modified for practical applications. Please contact our sales/engineering departments for further information and assistance.

DH

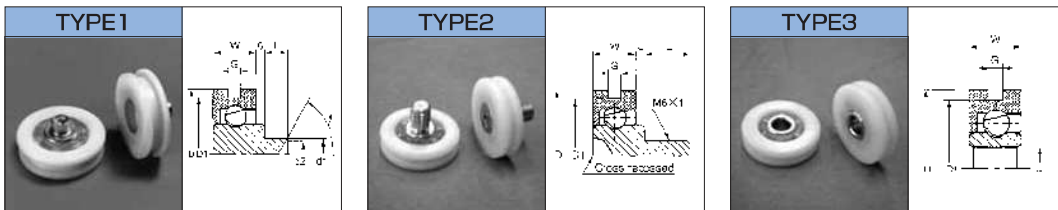

Code	Part No.	D ^{±0.2} [mm]	D1 ^{±0.2} [mm]	d ^{+0.1} ₀ [mm]	d1 _{-0.1} [mm]	W _{-0.2} [mm]	C ^{±0.4} [mm]	L ^{±0.2} [mm]	(d2× ϕ) ^{*1}	G ^{±0.2} [mm]	Type	Q'ty [pcs/box]	Gross Weight [kg/box]
100000	DH-16-A0.5	19	16	—	5	6	0.5	3.5	$\phi 4 \times 120^\circ$	2.1	1	2,000	10.9
101012	DH-16-B0.5	19	16	—	—	6	0.5	8 ^{±0.5}	—	2.1	2	2,000	12.5
101013	DH-16-B1	19	16	—	—	6	1	8 ^{±0.5}	—	2.1	2	2,000	11.8
101020	DH-19-B0.5-2	22	19	—	—	7	0.5	8 ^{±0.5}	—	2	2	1,000	9.9
101040	DH-21-B0.5-2	24	21	—	—	7	0.5	8 ^{±0.5}	—	2	2	1,000	10.5
102010	DH-16-H5	19	16	5	—	6	—	—	—	2.1	3	2,000	9.9
102021	DH-19-H6-2	22	19	6	—	7	—	—	—	2	3	1,000	9.6
102025	DH-19-H6-2.5	22	19	6	—	7	—	—	—	2.5	3	1,500	8.4
102040	DH-21-H6-2	24	21	6	—	7	—	—	—	2	3	1,000	7.3
102041	DH-21-H6-3	24	21	6	—	7	—	—	—	3	3	1,000	6.5
102042	DH-21-H6-3.2	24	21	6	—	7	—	—	—	3.2	3	1,000	6.2

*1 Reference Dimension

Size limits can be modified for practical applications. Please contact our sales/engineering departments for further information and assistance. These products are made to order.

TOK BEARING CO.,LTD.

HEAD OFFICE, TOKYO, JAPAN - TEL : 81-3-3969-1534 FAX : 81-3-3969-9354
EMAIL : overseas@tok-bearing.co.jp

Product specification are subject to change without prior notice.

Before assembly or use of any bearing, please read "Caution for Use"

D-SERIES ROLLERS

DL

DL

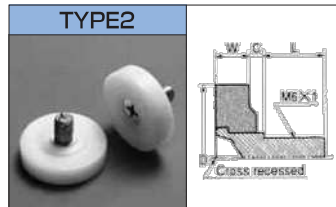
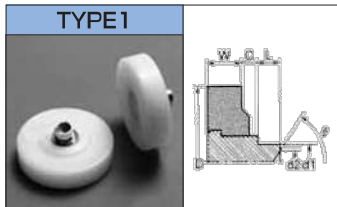

Code	Part No.	D _{-0.1} [mm]	d1 _{-0.1} [mm]	W _{-0.2} [mm]	C ^{±0.4} [mm]	L ^{±0.2} [mm]	(d2×θ) ^{*1}	Type	Q'ty [pcs/box]	Gross Weight [kg/box]
240012	DL-16-A0.5	16	4	5	0.5	3.6	nothing	1	2,500	3.2
240021	DL-19-A1.6	19	5	6.6	1.6	3.5	φ4×100°	1	2,000	10.4
240040	DL-22-A1.6	22	5	6.6	1.6 ^{±0.5}	3.5	φ4×100°	1	1,000	6.5
240080	DL-26-A1.6	26	5	6.6	1.6	3.5	φ4×100°	1	1,000	7.5
240120	DL-19-B1.6	19	—	6.6	1.6	8 ^{±0.5}	—	2	1,500	9.0
240140	DL-22-B1.6	22	—	6.6	1.6	8 ^{±0.5}	—	2	1,000	7.4
240159	DL-22-B2.6-7170	22	—	6.7 ^{±0.2}	2.6	8 ^{±0.5}	—	2	1,000	8.3
240145	DL-22-B5	22	—	6.7 ^{±0.2}	5	8 ^{±0.5}	—	2	1,000	9.9
240152	DL-22-B8.7	22 ^{±0.2}	—	7 ^{±0.2}	8.7	11 ^{±0.5}	—	2	1,000	11.7
240180	DL-26-B1.6	26	—	6.6	1.6	8 ^{±0.5}	—	2	1,000	9.0

***1 Reference Dimension**

Size limits can be modified for practical applications. Please contact our sales/engineering departments for further information and assistance.

TOK BEARING CO.,LTD.

HEAD OFFICE, TOKYO, JAPAN – TEL : 81-3-3969-1534 FAX : 81-3-3969-9354
EMAIL : overseas@tok-bearing.co.jp

Product specification are subject to change without prior notice.

Before assembly or use of any bearing, please read "Caution for Use"

I-SERIES BEARINGS

IDS

IDS

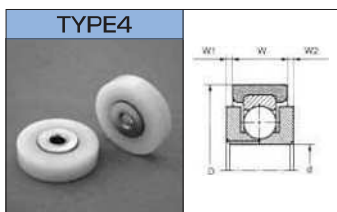
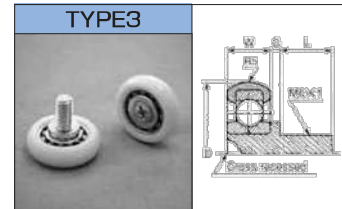
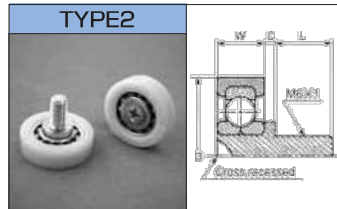
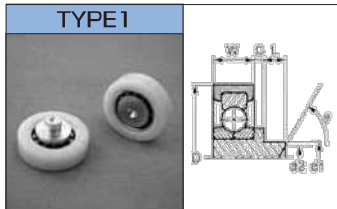

Code	Part No.	D ^{±0.1} [mm]	d ^{+0.1} [mm]	d1 _{-0.1} [mm]	W ^{±0.2} [mm]	C ^{±0.4} [mm]	L ^{±0.2} [mm]	^{*1} (d2 × θ)	W1 ^{*1} [mm]	W2 ^{*1} [mm]	Load ^{*2} [N] (kgf)	Type	Q'ty [pcs/box]	Gross Weight [kg/box]
221400	IDS-22-A1	22	—	5	7	1	3.5	φ2.5×90°	—	—	392 (40)	1	1,000	12.4
221401	IDS-22-A2.5	22	—	5	7	2.5	3.5	nothing	—	—	392 (40)	1	1,000	14.0
221403	IDS-22-A3.4-4.5	22	—	5.1	7	3.4	4.5	φ2.5×90°	—	—	392 (40)	1	1,000	13.4
221405	IDS-22-A9-5	22	—	4.2	7	9	5	nothing	—	—	392 (40)	1	1,000	15.2
221450	IDS-26-A1.5	26	—	6	8	1.5	3.5	φ5.5×90°	—	—	588 (60)	1	800	15.5
221504	IDS-22-B1.5-8	22	—	—	7	1.5	8 ^{±0.5}	—	—	—	392 (40)	2	1,000	13.2
221501	IDS-22-B1.5-11	22	—	—	7	1.5	11 ^{±0.5}	—	—	—	392 (40)	2	1,000	15.3
221505	IDS-22-B4-7	22	—	—	7	4	7 ^{±0.5}	—	—	—	392 (40)	2	1,000	14.5
221518	IDS-22-B11	22	—	—	7	11	8 ^{±0.5}	—	—	—	392 (40)	2	1,000	18.6
221600	IDS-26-B2-11	26	—	—	8	2	11 ^{±0.5}	—	—	—	588 (60)	2	500	10.2
221603	IDS-26-B5-9	26	—	—	8	5 ^{±0.5}	9 ^{±0.5}	—	—	—	588 (60)	2	500	11.1
221650	IDS-30-B2-11	30	—	—	9	2	11 ^{±0.5}	—	—	—	588 (60)	2	500	12.1
221700	IDS-26-B2-11	26 _{-0.2}	—	—	8	2	11 ^{±0.5}	—	—	—	588 (60)	3	500	10.2
221901	IDS-26-H6.35W0.8	26	6.35	—	8	—	—	—	0.8	0.8	294 (30)	4	800	16.3
221954	IDS-35-H6.35W0.26	35 _{-0.1}	6.35	—	9	—	—	—	0.26	0.26	294 (30)	4	500	13.3

*1 Reference Dimension

*2 Allowable Load at 300min -1 (300r.p.m.)

Size limits can be modified for practical applications. Please contact our sales/engineering departments for further information and assistance.

TOK BEARING CO.,LTD.

HEAD OFFICE, TOKYO, JAPAN – TEL : 81-3-3969-1534 FAX : 81-3-3969-9354
EMAIL : overseas@tok-bearing.co.jp

Product specification are subject to change without prior notice.

Before assembly or use of any bearing, please read "Caution for Use"

I-SERIES BEARINGS

IN/ID

IN

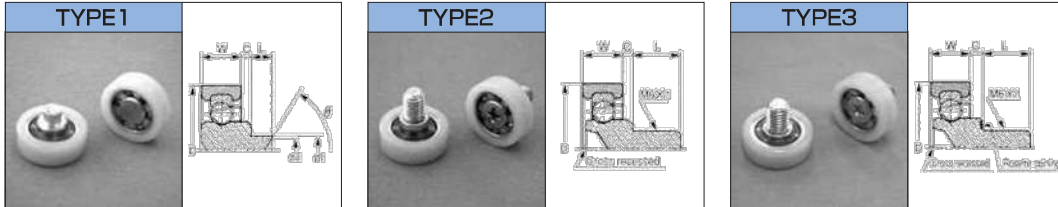

Code	Part No.	D _{-0.3} [mm]	d1 _{-0.1} [mm]	W ^{±0.2} [mm]	C ^{±0.4} [mm]	L ^{±0.2} [mm]	(d2×θ) ^{*1}	Load ^{*2} [N] (kgf)	Type	Q'ty [pcs/box]	Gross Weight [kg/box]
220000	IN-19-A1.5	19	5	7	1.5	3.5	φ4.4×120°	49 (5)	1	1,500	7.4
220011	IN-19-B1	19	—	7	1	8 ^{±0.5}	—	196 (20)	2	1,500	12.2
220013	IN-19-B2.7	19	—	7	2.7	8 ^{±0.5}	—	196 (20)	2	1,500	13.4
220014	IN-19-B3	19	—	7	3	8 ^{±0.5}	—	196 (20)	2	1,500	13.5
220010	IN-19-B0.5	19	—	7	0.5	8 ^{±0.5}	—	196 (20)	3	1,500	11.9
220012	IN-19-B1.5	19	—	7	1.5	8 ^{±0.5}	—	196 (20)	3	1,500	12.5

*1 Reference Dimension

*2 Allowable Load at 300min -1 (300r.p.m.)

Size limits can be modified for practical applications. Please contact our sales/engineering departments for further information and assistance.

ID

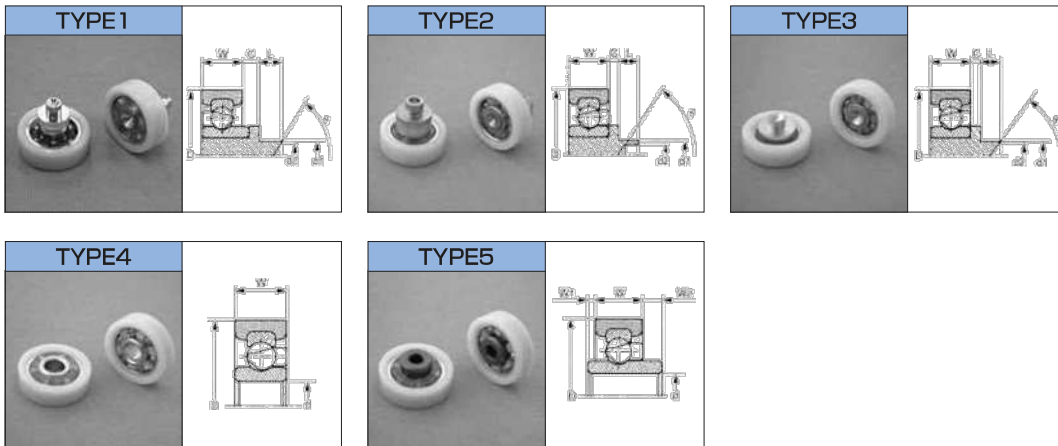

Code	Part No.	D _{-0.3} [mm]	d _{+0.1} [mm]	d1 _{-0.1} [mm]	W ^{±0.2} [mm]	C ^{±0.4} [mm]	L ^{±0.2} [mm]	(d2×θ) ^{*1}	W1 ^{*1} [mm]	W2 ^{*1} [mm]	Load ^{*2} [N] (kgf)	Type	Q'ty [pcs/box]	Gross Weight [kg/box]
221101	ID-18.8-AH5	18.8	—	4	7	5	3.5	φ3 × 90°	—	—	333 (35)	1	1,500	13.0
221100	ID-18.8-AH5-5	18.8	—	4	7	5	5	φ3 × 90°	—	—	333 (35)	1	1,500	13.4
221102	ID-19-AH2.5	19 _{-0.3}	—	5	7	2.5	3.5	φ3 × 120°	—	—	333 (35)	2	1,500	12.9
221103	ID-19-AH5.5	19 _{-0.3}	—	5	7	5.5	3.5	φ3 × 120°	—	—	333 (35)	2	1,500	15.9
221110	ID-24-AH1-3.6	24 ^{±0.2}	—	6	8	1	3.6	φ5.5× 90°	—	—	333 (35)	3	1,000	12.3
221301	ID-19-H6	19 _{-0.3}	6	—	7	—	—	—	—	—	333 (35)	4	2,000	10.5
221303	ID-22-H6	22	6	—	7	—	—	—	—	—	333 (35)	4	1,500	22.5
221304	ID-22-H4W (0.5) 3	22	4	—	7	—	—	—	0.5	3	333 (35)	5	1,000	10.2

*1 Reference Dimension

*2 Allowable Load at 300min -1 (300r.p.m.)

Size limits can be modified for practical applications. Please contact our sales/engineering departments for further information and assistance.

TOK BEARING CO.,LTD.

HEAD OFFICE, TOKYO, JAPAN – TEL : 81-3-3969-1534 FAX : 81-3-3969-9354
EMAIL : overseas@tok-bearing.co.jp

Product specification are subject to change without prior notice.

Before assembly or use of any bearing, please read "Caution for Use"

A-SERIES BEARINGS

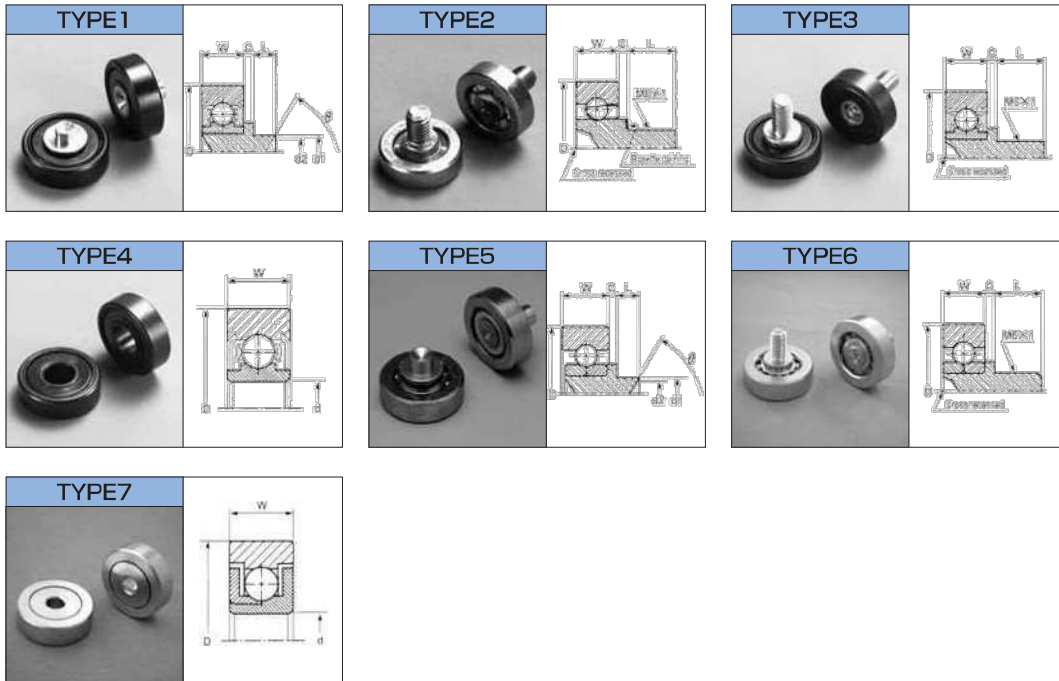

Code	Part No.	D ^{±0.1} [mm]	d ^{+0.1} [mm]	d1 _{-0.1} [mm]	W ^{±0.2} [mm]	C ^{±0.4} [mm]	L ^{±0.2} [mm]	(d2 × θ) ^{*1}	Load ^{*2} [N] (kgf)	Type	Q'ty [pcs/box]	Gross Weight [kg/box]
230050	A-22-AH1-3.4	22	—	5	7	1	3.4	φ4.5×110°	784 (80)	1	1,000	16.2
230203	A-19-B1	19	—	—	6	1	8 ^{±0.5}	—	490 (50)	2	1,000	12.1
230204	A-19-B2	19	—	—	6	2	8 ^{±0.5}	—	490 (50)	2	1,000	12.7
230207	A-19-B2.7	19	—	—	6	2.7	8 ^{±0.5}	—	490 (50)	2	1,000	12.8
230251	A-22-BH2.8-11	22	—	—	7	2.8	11 ^{±0.5}	—	784 (80)	3	1,000	18.0
800000	A-608ZZ-5	22	8	—	7	—	—	—	784 (80)	4	1,000	10.8
231010	AS-19-A0.5-5	19 ^{±0.05}	—	5	6 ^{±0.1}	0.5 ^{±0.3}	5	φ4.5×100~130°	490 (50)	5	1,000	19.0
231050	AS-22-A1.5	22	—	6	8	1.5	3.5	φ5.5×90°	686 (70)	5	1,000	18.0
231052	AS-22-A1.5-5.5	22	—	6	8	1.5	5.5	φ5 ×110°	686 (70)	5	1,000	20.1
231150	AS-26-A1.5	26	—	6	8	1.5	3.5	φ5.5×90°	686 (70)	5	800	23.2
231203	AS-22-B0.5-9.5	22	—	—	8	0.5	9.5 ^{±0.5}	—	686 (70)	6	1,000	19.9
231204	AS-22-B2-11	22	—	—	8	2	11 ^{±0.5}	—	686 (70)	6	1,000	21.5
231250	AS-24-B0.5-9.5	24	—	—	8	0.5	9.5 ^{±0.5}	—	686 (70)	6	500	12.3
231300	AS-26-B2-11	26	—	—	8	2	11 ^{±0.5}	—	686 (70)	6	500	15.5
231402	AS-608ZZ-2	22	8	—	7	—	—	—	294 (30)	7	500	7.6
231405	AS-26-H6	26	6	—	8 ^{±0.3}	—	—	—	294 (30)	7	800	27.8

*1 Reference Dimension *2 Allowable Load at 300min -1 (300r.p.m.)

Size limits can be modified for practical applications. Please contact our sales/engineering departments for further information and assistance.

C/PK/PV/PE/S-SERIES BEARINGS

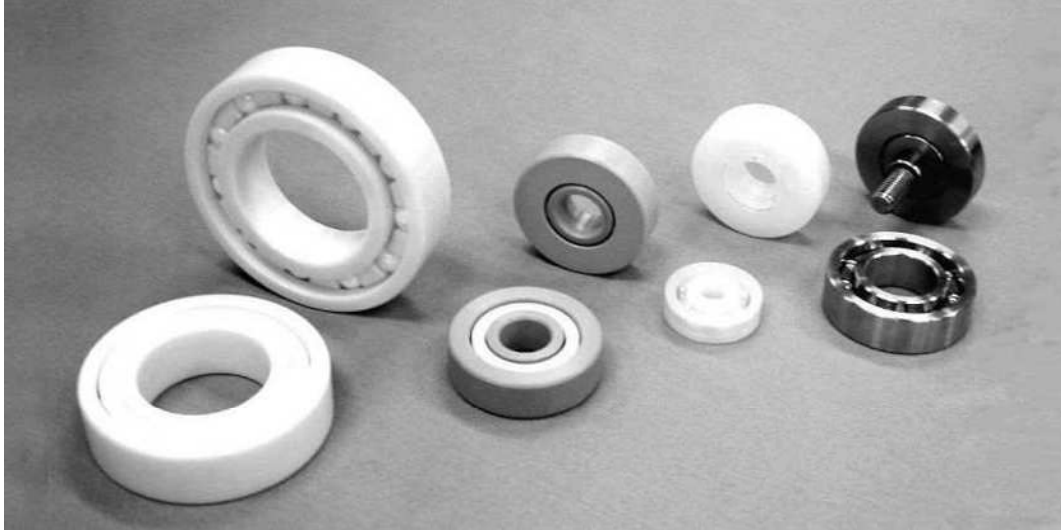

CORROSION AND CHEMICAL RESISTANT BEARINGS

PRIMARY USAGE IN THE MEDICAL AND SEMICONDUCTOR INDUSTRIES

Features

1. Excellent Chemical resistance (depending on environment)
2. Excellent Corrosion resistance (depending on environment)
3. Excellent Heat resistance (depending on environment)
4. Waterproof

Applications

Ideal for use in the medical and semiconductor industries where products are subject to harsh Chemicals and environments. Other applications would be in industries using high temperatures such as transportation and cleaning.

C-SERIES BEARINGS

CERAMIC

CHARACTERISTICS

Major characteristics of a ceramic bearing are: excellent corrosion and chemical resistance; self lubricating (absence of grease); and non-magnetic. Recommended environments include, but are not limited to: etching, cleaning, coating, medical, and testing equipment.

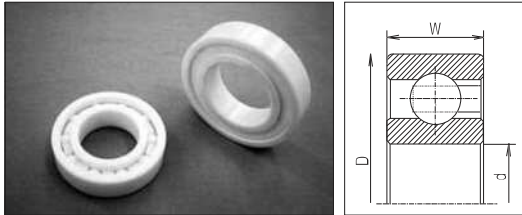

Code	Part No.	JIS	D _{-0.02} [mm]	d _{+0.02} [mm]	W _{-0.1} [mm]	Balls material	Outer and Inner races material	Retainer material
	C-26-CHC10	6000	26	10	8	ZrO ₂	ZrO ₂	PTFE
	C-28-CHC12	6001	28	12	8	ZrO ₂	ZrO ₂	PTFE
	C-30-CHC10	6200	30	10	9	ZrO ₂	ZrO ₂	PTFE
	C-32-CHC12	6201	32	12	10	ZrO ₂	ZrO ₂	PTFE
	C-32-CHC15	6002	32	15	9	ZrO ₂	ZrO ₂	PTFE
	C-35-CHC15	6202	35	15	11	ZrO ₂	ZrO ₂	PTFE
	C-35-CHC17	6003	35	17	10	ZrO ₂	ZrO ₂	PTFE
	C-40-CHC17	6203	40	17	12	ZrO ₂	ZrO ₂	PTFE
	C-42-CHC20	6004	42	20	12	ZrO ₂	ZrO ₂	PTFE
	C-47-CHC20	6204	47	20	14	ZrO ₂	ZrO ₂	PTFE
	C-47-CHC25	6005	47	25	12	ZrO ₂	ZrO ₂	PTFE
	C-52-CHC25	6205	52	25	15	ZrO ₂	ZrO ₂	PTFE
	C-55-CHC30	6006	55	30	13	ZrO ₂	ZrO ₂	PTFE
	C-62-CHC30	6206	62	30	16	ZrO ₂	ZrO ₂	PTFE
	C-62-CHC35	6007	62	35	14	ZrO ₂	ZrO ₂	PTFE
	C-68-CHC40	6008	68	40	15	ZrO ₂	ZrO ₂	PTFE
	C-72-CHC35	6207	72	35	17	ZrO ₂	ZrO ₂	PTFE
	C-80-CHC40	6208	80	40	18	ZrO ₂	ZrO ₂	PTFE

Inner gap is under C4 (within 0.03mm)

Can be designed and produce in different sizes

Material: Ball and outer/inner races-Zirconia (ZrO₂); retainer — polytetrafluoroethylene (PTFE)

Guide to Corrosion Resistance

Use liquid	Material	Si ₃ N ₄	ZrO ₂	PTFE
Salt-Water		◎	◎	◎
Potassium Hydroxide		△	△	◎
Sodium Hydroxide		△	○	◎
Hydrofluoric acid		△	▲	◎
Phosphoric Acid		○	○	◎
Sulphuric Acid		○	○	◎
Hydrochloric Acid		△	○	◎
Nitric Acid		○	○	◎

◎ : anticorrosive
 ○ : hardly corrosive
 △ : slight corrosive
 ▲ : possibility of corrosiveness

※Chemical and corrosion resistance will vary depending on chemical concentrations and temperatures.

(Guide to Corrosion resistance, is only a reference. For more information Please contact our sales and engineering departments for assistance)

TOK BEARING CO.,LTD.

HEAD OFFICE, TOKYO, JAPAN — TEL : 81-3-3969-1534 FAX : 81-3-3969-9354
 EMAIL : overseas@tok-bearing.co.jp

Product specification are subject to change without prior notice.

Before assembly or use of any bearing, please read "Caution for Use"

S-SERIES BEARINGS

DR-S

DR-S

The outer races are made of polyacetal resin and the inner races and balls are made of stainless steel.

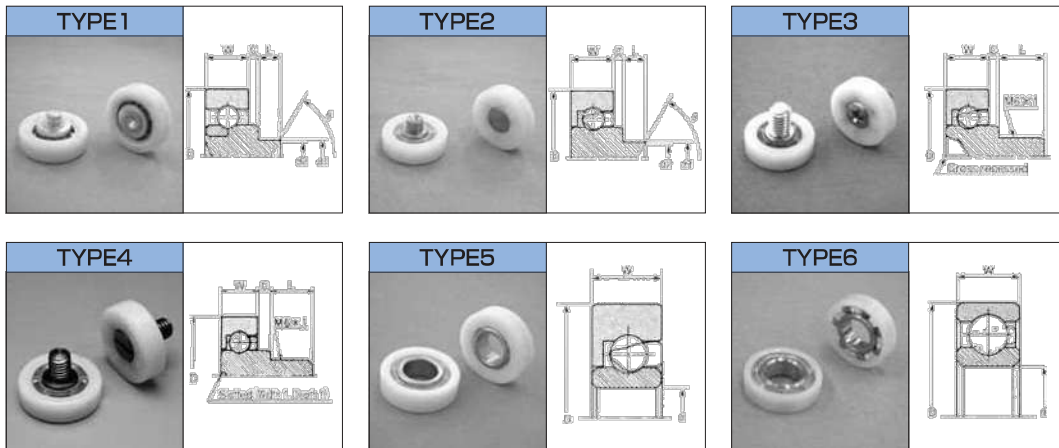

Code	Part No.	D ^{-0.1} [mm]	d ^{+0.1} [mm]	d1 ^{-0.1} [mm]	W ^{-0.2} [mm]	C ^{±0.4} [mm]	L ^{±0.2} [mm]	(d2 × θ) ^{*1}	Load ^{*2} [N] (kgf)	Type	Q'ty [pcs/box]	Gross Weight [kg/box]
000002	DRS-16-SAS1-GN	16 ^{-0.3}	—	4	5 ^{±0.2}	1	3.5	φ3 × 100°	—	1	2,000	9.0
000202	DR-19-SAS0.5-GN	19	—	5	6	0.5	3.5 ^{-0.2}	φ4 × 120°	—	2	2,000	10.7
000421	DR-22-SAS1	22	—	5	7	1 ^{±0.3}	3.4 ^{±0.1}	φ4 × 90°	—	2	1,000	9.0
020202	DR-19-SBS0.5	19	—	—	6	0.5	8 ^{±0.5}	—	—	3	2,000	12.5
020442	DR-22-SBS0.5-GN	22	—	—	7	0.5	8 ^{+0.5}	—	—	4	1,000	9.8
020735	DR-26-SBS0.5	26	—	—	7	0.5	8 ^{±0.5}	—	—	4	1,000	10.1
021001	DR-30-SBS0.5	30	—	—	7	0.5 ^{±0.3}	8 ^{±0.5}	—	—	4	500	6.8
021100	DR-35-SBS0.5	35	—	—	7	0.5 ^{±0.3}	8 ^{±0.5}	—	—	4	300	4.0
040101	DR-18-SHS6-GN	18	6	—	6	—	—	—	—	5	2,500	7.8
040207	DR-19-SHS6	19	6	—	6	—	—	—	—	5	2,500	8.1
040404	DR-22-SHS6-GN	22	6	—	7	—	—	—	—	5	1,000	7.0
040414	DR-22-SHS8-GN	22	8	—	7	—	—	—	—	5	1,000	5.3
040801	DR-28-SHS6-GN	28	6	—	7	—	—	—	—	5	500	4.2
041601	DR-26-SHS10-GN	26	10	—	8	—	—	—	98 (10)	5	1,000	7.9
041611	DR-30-SHS10-GN	30	10	—	9	—	—	—	147 (15)	5	500	7.7
041613	DR-32-SHS12-GN	32	12	—	10	—	—	—	176 (18)	5	500	9.6
041615	DR-35-SHS15-GN	35	15	—	11	—	—	—	176 (18)	5	400	10.6
041617	DR-40-SHS17-GN	40	17	—	12	—	—	—	205 (21)	5	250	6.9
041619	DR-47-SHS20-GN	47	20	—	14	—	—	—	235 (24)	5	150	8.7
040103	DR-18-SHS8	18	8	—	5	—	—	—	—	6	3,000	8.7

*1 Reference Dimension *2 Allowable Load at 300min-1 (300r.p.m.)

Size limits can be modified for practical applications. Please contact our sales/engineering departments for further information and assistance. These products are made to order.

PK/PV-SERIES BEARINGS

PEEK/PVDF

PEEK/PVDF

CHEMICAL AND HEAT RESISTANCE BEARINGS:

PEEK/PVDF bearings have much better chemical and heat resistance than our conventional PE SERIES BEARINGS. These bearings are suitable for use in these environments: automated systems used in chemical processing; transportation systems used in chemical processing; washing and cleaning systems used in the medical and semiconductor industries where chemical solution and high heat are present.

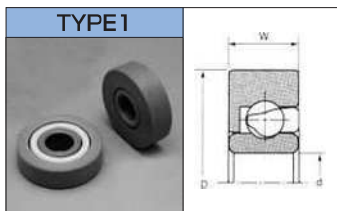

Code	Part No.	D _{-0.1} [mm]	d _{+0.12} [mm]	W _{-0.2} [mm]	Balls material *1	Outer and Inner races*2	Retainer material *3
801009	PK-30-GHP10	30	10	9	ガラス	PEEK	PTFE
—	PV-30-GHP10	30	10	9	ガラス	PVDF	PTFE
—	PK-32-GHP12	32	12	10	ガラス	PEEK	PTFE
—	PV-32-GHP12	32	12	10	ガラス	PVDF	PTFE
—	PK-35-GHP15	35	15	11	ガラス	PEEK	PTFE
—	PV-35-GHP15	35	15	11	ガラス	PVDF	PTFE

- *1 Ball Material: G=Glass. Ceramic balls can be used, please contact our sales/engineering department for more details.
- *2 Outer/Inner Race Material: PEEK=Polyetheretherketone; PVDF=Polyvinylidene fluoride.
- *3 Retainer Material: PTFE=Polytetrafluoroethylene.
- *4 Size limits can be modified for practical applications. Please contact our sales/engineering departments for further information and assistance.
These bearings are lubricant free and are made to order.

Materials	Chemical Resistance Resin					Other Resin			
	P T F E	P C T F E	P V D F	P E E K	U H M W P E	P A	P O M	P P	P V C
Temperature Resistance [°C]	130	80	80	130	60	70	50	50	35
Mechanical	△	○	○	◎	○	○	◎	○	○
Electrical	◎	○	○	◎	△	△	△	◎	△
Chemical proof	Acid	◎	◎	○	○	×	×	○	○
	Alkalis	◎	◎	○	◎	×	△	○	○
	Solvents	◎	○	○	◎	△	×	○	△

Information provided is for reference only.
Materials only reflect standard characteristics provided by technical books and material supplier's catalogs.

(Explanation of Codes)

- ◎ : GOODAcceptable—Visually free of any corrosive affect. Durable for field applications.
- : FAIRLimited—Slight corrosion influence, but can be used for specific field applications in ambient conditions
- △ : AVERAGEUnacceptable—Yelding and not applicable
- × : IMPROPERNo rating—easily corrodes and not usable

TOK BEARING CO.,LTD.

HEAD OFFICE, TOKYO, JAPAN – TEL : 81-3-3969-1534 FAX : 81-3-3969-9354
EMAIL : overseas@tok-bearing.co.jp

Product specification are subject to change without prior notice.

Before assembly or use of any bearing, please read "Caution for Use"

PE-SERIES BEARINGS

PE

PE ULTRA-HIGH MOLECULAR WEIGHT POLYETHYLENE (ANTI-ACID/ANTI-ALKALI BEARINGS)

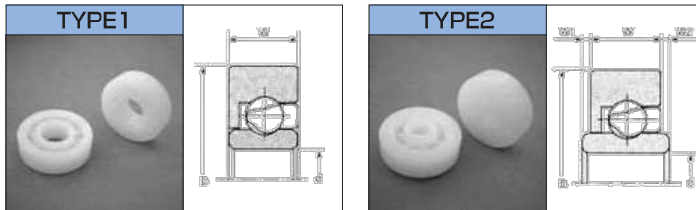

Code	Part No.	D _{-0.1} [mm]	d ^{+0.12} ₀ [mm]	W _{-0.2} [mm]	W1 ^{*1} [mm]	W2 ^{*1} [mm]	Type	Q'ty [pcs/box]	Gross Weight [kg/box]	BALL ^{*2}
250126	PE-35-SHP15	35	15 ^{+0.15} ₀	11	—	—	1	400	5.3	S
250010	PE-35-SHP8W1.75	35	8	11	1.75	1.75	2	300	3.7	S
250017	PE-35-SHP17W1.75	35	17 ^{+0.2} ₀	11	1.75	1.75	2	400	4.8	S
250100	PE-26-PHP10	26 _{-0.2}	10	8	—	—	1	1,000	2.9	P
250121	PE-30-PHP10	30	10	9	—	—	1	500	2.2	P
250124	PE-32-PHP12	32	12 ^{+0.2} ₀	10	—	—	1	500	3	P
250127	PE-35-PHP15	35	15 ^{+0.15} ₀	11	—	—	1	400	2.5	P
250132	PE-47-PHP20	47	20	14	—	—	1	150	4	P
250011	PE-35-PHP8W1.75	35	8	11	1.75	1.75	2	300	3.4	P
250122	PE-30-GHP10	30	10	9	—	—	1	500	6	G
250131	PE-40-GHP17	40	17	12	—	—	1	300	3.7	G
250012	PE-35-GHP8W1.75	35	8	11	1.75	1.75	2	300	3.1	G
250019	PE-35-GHP17W1.75	35	17 ^{+0.2} ₀	11	1.75	1.75	2	400	3.5	G

*1 Reference Dimension

*2 Ball Material: S=Stainless Steel; P=Polyethylene; G=Glass. Outer/Inner Race Material: Ultra-high Molecular Weight Polyethylene.

*3 Size limits can be modified for practical applications. Please contact our sales/engineering departments for further information and assistance. These bearings are lubricant free and are made to order.

DURABILITY OF PLASTICS IN A CHEMICAL ENVIRONMENT

Table No.1 : durability of plastics in a chemical environment

	Polyacetal (POM)	Polyamid (PA)	Polyethylene (PE)	Polypropylene (PP)
Liquid Ammonia	○	○	○	○
Calcium Hydroxide	○	○	○	○
Potassium Hydroxide	○	○	○	○
Sodium Hydroxide	30%, 30C	○	○	○
	30% RT	○	○	○
	10% RT	○	○	○
Oxalic Acid	△	△	○	○
Acetic Acid	△	△	○	○
Hydrochloric Acid	50% RT	△	○	○
	38% RT	△	○	○
	10% RT	○	○	○
Nitric Acid	RT Fuming RT	×	×	×
	61% RT	×	△	△
	10% RT	△	○	○
Sulphuric Acid	RT Fuming RT	×	×	△
	98% RT	×	△	△
	10% RT	△	○	○
Chromic Acid	×	×	○	△

Table No.1 denotes the durability of Polyacetal, Polyamid(nylon), Polyethylene, and Polypropylene, against acids and alkali solutions.

Table No.2 : durability of plastics against solvent, oil, gasses and sea water

	Polyacetal (POM)	Polyamid (PA)	Polyethylene (PE)	Polypropylene (PP)
Sea-Water	○	*	○	○
Sulfur Dioxide Gas	○	○	○	○
Carbonic Acid Gas	○	○	○	○
Ammonia	○	○	○	○
Petroleum	○	○	△	△
Benzine	△	○	△	△
Holmaldehyde	△	△	○	○
Ethyl Alcohol	○	○	○	○
Cresol	○	×	○	○

Bearing used in sea water, must be corrosion resistance to sea water.

*polyamide resins water absorption ratios are too high to be considered for use as balls or races in a water or sea water environment.

(Explanation of Codes)

○ : GOOD Acceptable—Visually free of any corrosive affect. Durable for field applications.
 ○ : FAIR Limited—Slight corrosion influence, but can be used for specific field applications in ambient conditions.
 △ : AVERAGE Unacceptable—Yielding and not applicable
 × : IMPROPER No rating—easily corrodes and not usable
 RT : Room Temperature

S-SERIES BEARINGS

SUS

SUS

(ALL STAINLESS STEEL BEARINGS)

These bearings are made of stainless steel.

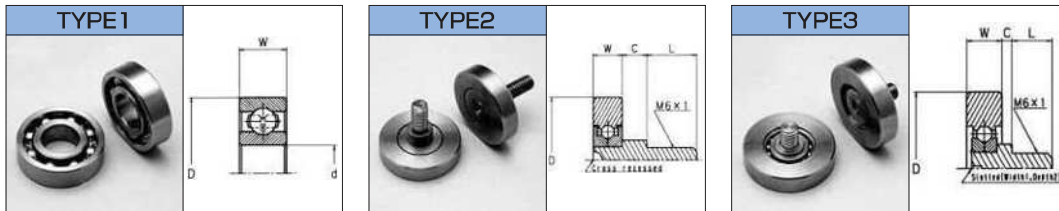

Code	Part No.	D _{-0.03} [mm]	d ^{+0.05} [mm]	W _{-0.05} [mm]	C ^{±0.4} [mm]	L ^{±0.5} [mm]	Outer races material	Inner races material	Shaft material	Retainer material	Balls material	Type
233002	S-16-SHS8-304-GN	16	8	4	—	—	SUS304	SUS304	—	SUS304	SUS304	1
233003	S-22-SHS8-304-GN	22	8	7	—	—	SUS304	SUS304	—	SUS304	SUS304	1
233007	S-22-SHS10-304-GN	22	10	6	—	—	SUS304	SUS304	—	SUS304	SUS304	1
233008	S-24-SHS12-304-GN	24	12	6	—	—	SUS304	SUS304	—	SUS304	SUS304	1
233009	S-26-SHS9-304-GN	26	9	8	—	—	SUS304	SUS304	—	SUS304	SUS304	1
233000	S-28-SHS12-304-GN	28	12	8	—	—	SUS304	SUS304	—	SUS304	SUS304	1
233001	S-28-SHS15-304-GN	28	15	7	—	—	SUS304	SUS304	—	SUS304	SUS304	1
233005	S-30-SHS10-304-GN	30	10	9	—	—	SUS304	SUS304	—	SUS304	SUS304	1
233004	S-30-SHS17-304-GN	30	17	7	—	—	SUS304	SUS304	—	SUS304	SUS304	1
233006	S-32-SHS12-304-GN	32	12	10	—	—	SUS304	SUS304	—	SUS304	SUS304	1
232050	SS-22-SBS2	22 _{-0.1}	—	7 ^{±0.2}	2	8	SUS303	SUS303	SUS305	—	SUS304	2
232055	SS-30-SBS6-12	30 ^{±0.1}	—	7 _{-0.2}	6	12	SUS303	SUS303	SUS305	—	SUS440C	2
232060	SS-30-SBS0.5	30 _{-0.1}	—	7 _{-0.2}	0.5	8	SUS303	SUS303	SUS303	—	SUS304	3

Size limits can be modified for practical applications. Please contact our sales/engineering departments for further information and assistance. These products are made to order.

CORROSION RESISTANCE OF STAINLESS STEEL

Table No.1—Corrosion resistance of stainless steel

	SUS 304	SUS 316
Sea-Water	A*	A*
20°C Sulfurous Acid (Saturation) 20°C	C	B
Liquid Ammonia	Boiling	A
	20°C	A
Ethyl Alcohol	Boiling	A
	20°C	A
Ammonia	Gas-High Temperature	D
	Whole Density 20°C	A
Sodium Hydroxide	A	A
Oxalic Acid 10% 20°C	A	A
Acetic Acid 50% 20°C	A	A
Hydrochloric Acid Whole Density 20°C	E	E
Nitric Acid	65% Boiling	B
	20% 20°C	A
Sulphuric Acid	50% 20°C	D
	5% Boiling	E
5% 20°C	C	B

Stainless Steel has a high resistance to corrosion. However, it is not corrosion free and will corrode in certain environments and over time. Precautions should be taken when using the table and research should be used to determine whether or not Stainless Steel is suitable for your application.

(Explanation of Codes)
code Weight Reduction by Corrosion
A..... ≤0.1 | usable
B..... 0.1~1.0 | Slightly corroded
C..... 1.0~3.0 | Gets corroded
D..... 3.0~10.0 | Badly corroded
E..... ≥10.0 | Corrosion spots appear when dehydrated
*..... Corrosion spots appear when dehydrated

TOK BEARING CO.,LTD.

HEAD OFFICE, TOKYO, JAPAN - TEL : 81-3-3969-1534 FAX : 81-3-3969-9354
EMAIL : overseas@tok-bearing.co.jp

Product specification are subject to change without prior notice.

Before assembly or use of any bearing, please read "Caution for Use"

BEARINGS

OTHERS

SPECIAL BEARINGS

We can supply bearings for various applications.

DT SERIES BEARING

- Features:
1. A steel bearing with an insert-molded polyacetal resin
 2. Run-out and clearance of the bearings are small.
 3. Because of the insert-molded polyacetal operational noise levels are very low.

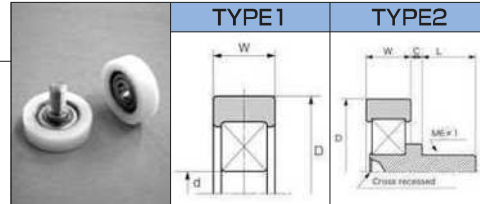

Code	Part No.	D ^{+0.15}	d	W ^{+0.2}	C ^{+0.4}	L ^{+0.5}	TYPE
110070	DT-22-688ZZ	22 ^{+0.1}	(8)	7 ^{0/-0.1}	—	—	1
110056	DT-26-H6-626ZZ	26	(6)	8	—	—	1
110058	DT-26-BH0.5-626ZZ	26	—	8	0.5	8	2
110057	DT-26-BH2.9.5-626ZZ	26	—	8	2	9.5	2
110060	DT-26-BH4-626ZZ	26	—	8	4	8	2
110059	DT-26-BH6-14-626ZZ	26	—	8	6	14	2

*Size limits can be modified for practical applications. Please contact our sales/engineering departments for further information and assistance. These products are made to order.

ER NON-ELECTRIFICATION BEARING

- Features:
- Electrification of static electricity is preventive by using conductive resins for the outer races and electric conduction grease.

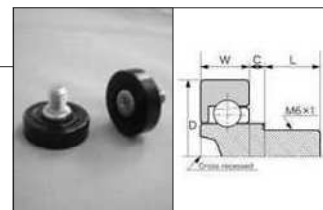

Code	Part No.	D	W	C ^{±0.4}	L ^{±0.5}
720104	ER-19-B0.5	19 ^{0/-0.1}	6 ^{+0.2}	0.5	8
720101	ER-22-B2	22 ^{+0.2}	7 ^{-0.2}	2	8
720102	ER-22-B6	22 ^{+0.2}	7 ^{-0.2}	6	8
720103	ER-26-B0.5	26 ^{+0.3/-0.1}	7 ^{-0.3}	0.5	8

*Size limits can be modified for practical applications. Please contact our sales/engineering departments for further information and assistance. These products are made to order.

Electric resistance value (reference)

unit : kΩ

sample	1	2	3	4	average
electric resistance	174.8	221.8	221.5	131.3	187.4

*An electrical resistance value of the bearing between outer race and inner race is measured after applying radial load, 49N (5kg), to the bearings for 3minutes.

UT SERIES BEARING

- Features:
1. A JIS bearing which is insert-molded using polyurethane resins.
 2. Because of the insert-molded polyurethane operational noise levels are very low.
 3. Due to the polyurethane molding it is very difficult to damage the bearing.

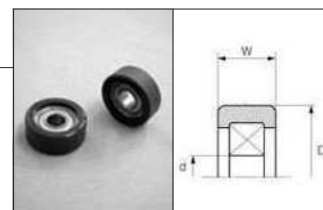

Code	Part No.	D _{2.3}	d	W ^{±0.2}	Load (N) *
110032	UT-20-696ZZ	20	(6)	8	29.4

*Allowable load at 300min⁻¹ (300r.p.m)

Size limits can be modified for practical applications. Please contact our sales/engineering departments for further information and assistance. These products are made to order.

TOK BEARING CO.,LTD.

HEAD OFFICE, TOKYO, JAPAN - TEL : 81-3-3969-1534 FAX : 81-3-3969-9354
EMAIL : overseas@tok-bearing.co.jp

Product specification are subject to change without prior notice.

Before assembly or use of any bearing, please read "Caution for Use"

BEARINGS

DURABLE AND NON-DESTRUCTIVE BEARING (TOUGH)

FEATURES: The "TAS" bearings are very durable and tough to destroy. New technology was used to increase its durable and shock resistance.

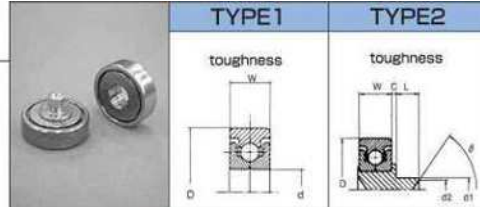

Code	Part No.	D _{-0.1} [mm]	d ^{+0.1} ₀ [mm]	d1 _{-0.1} [mm]	W _{-0.02} [mm]	C ^{+0.4}	L ^{+0.3} ₀	(d2 x θ)	Load ^{*)} [N] (kgf)	TYPE
231502	TAS-22-H8	22	8	-	7	-	-	-	392 (40)	1
231501	TAS-22-AH1-5	22	-	5	7	1	5	φ3 x 100°	392 (40)	2

*Allowable load at 300rpm
Size limits can be modified for practical applications. Please contact our sales/engineering departments for further information and assistance.

1. Compression examination

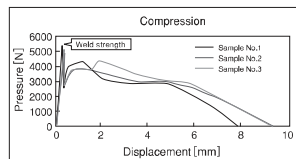
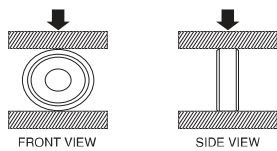

With a fixed outer wheel, the TAS bearing has a compression strength of about 1.5X the JIS bearing 608ZZ

2. Compression examination

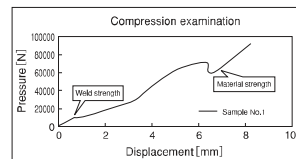
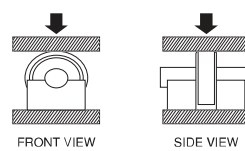

When an inside fix is used, the TAS bearing has a compression strength of approximately 23X the JIS bearing 608ZZ

3. Motive power examination

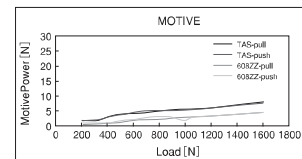
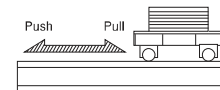

In Motive power, the TAS bearing is equal to the JIS bearing 608ZZ

THRUST RETAINER

FEATURES : 1. This is simple Thrust bearing with a press-fit ball in the retainer.
2. Axial load can be applied in one direction.

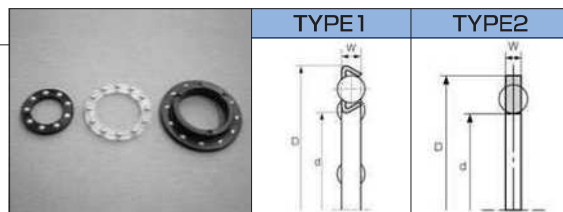

Code	Part No.	D	d	W	Retainer material	Balls material	Balls	TYPE
800002	T-22 Thrust Reatiner	21.4 ^{+0.2}	13 ^{±0.1}	2 ^{±0.1}	SUS304	SUJ-2	1/8" x 12	1
280300	T-22.7 Nylon Thrust Reatiner	22.7 ^{+0.1}	16 ^{+0.1} ₀	1.4 ^{±0.1}	PA66	SUJ-2	3/32" x 12	2

*Size limits can be modified for practical applications. Please contact our sales/engineering departments for further information and assistance.
These bearings are made to order.

TOK BEARING CO.,LTD.

HEAD OFFICE, TOKYO, JAPAN - TEL : 81-3-3969-1534 FAX : 81-3-3969-9354
EMAIL : overseas@tok-bearing.co.jp

Product specification are subject to change without prior notice.
Before assembly or use of any bearing, please read "Caution for Use"

SLIDING DOOR WHEELS

UNIVERSAL TYPE-SLIDING DOOR WHEELS

APPLICATIONS: All types of sliding doors

FEATURES: 1. Clamps are not required in the assembly of the doors
2. Simple construction, high durability, and low cost
3. Free from corrosion, 100% plastic material

DURABILITY: The door wheels were tested under the following conditions:
• Forward and Reverse Force of 49N(kgf)
• Stroke of 500mm for 100,000 cycles
The result : the door wheels and door should still smoothly.

Code	Part NO.	Frame material	Kind of roller
260001	TOK DOOR WHEEL No.3 A	Polyethylene (PE)	Roller (PA : Polyamide)
260005	TOK DOOR WHEEL No.3 B	Polyethylene (PE)	Bearing (DU-30-H6-M)



TOK DOOR WHEEL No.3 A (Roller type)

Sizes of Hole for snap-in fit
L×W×t=40.5×11×1.0 (or 0.8) mm

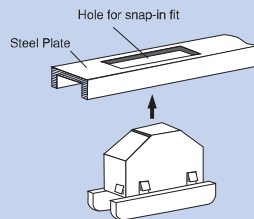

Fitting method

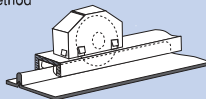

TOK DOOR WHEEL No.3 B (Bearing type)

Dimension

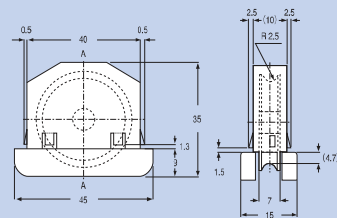

SLIDING DOOR WHEELS

GLASS SLIDING DOOR WHEEL/ ROLLER SET SCREEN V

APPLICATIONS: For glass doors, such as display cases
 TYPES: Glass Sliding Door Wheel: Bearing (DRS-16-H4.1WO.25)
 Roller set screen V: Roller (POM: Polyacetal)

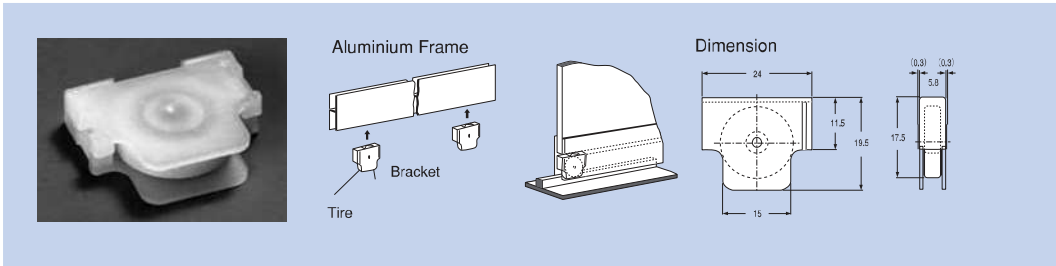

Code	Part NO.	Frame material	Kind of roller
260000	GLASS DOOR WHEEL	Polyethylene (PE)	Bearing (DRS-16-H4.1WO.25)
260068	ROLLER SET SCREEN V	Polyamide (PA)	Roller (POM : Polyacetal)

UNIVERSAL TYPE SLIDING DOOR WHEELS WITH ADJUSTABLE HOUSING

APPLICATIONS: All types of sliding doors
 FEATURES: 1. Easy installation without clamps
 2. Free from corrosion, 100% plastic material
 3. Smooth sliding with D-SERIES BEARINGS
 MODELS: 2 types are available:
 · ADJUSTABLE DOOR WHEEL F
 · ADJUSTABLE DOOR WHEEL No.7

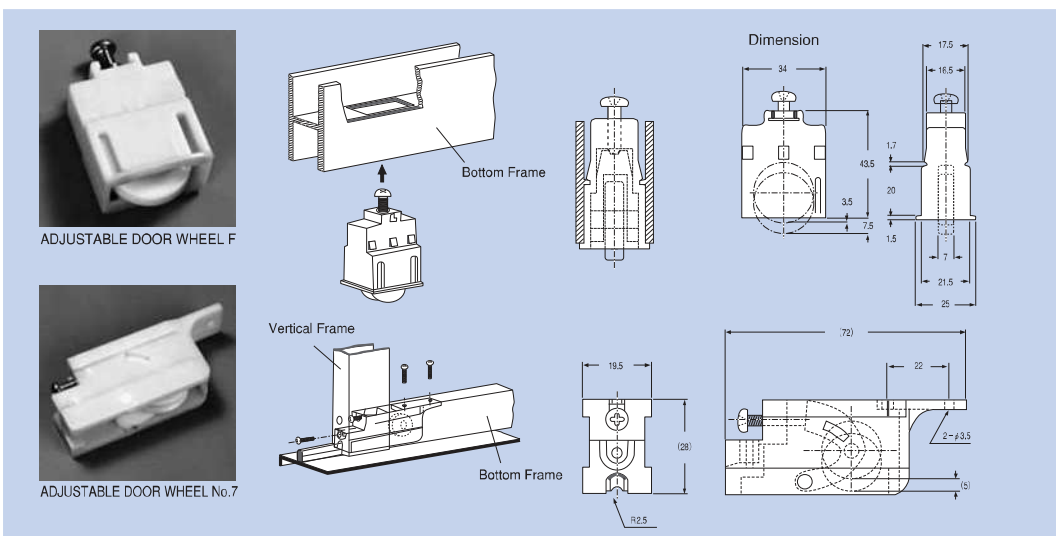

TOK BEARING CO.,LTD.

HEAD OFFICE, TOKYO, JAPAN – TEL : 81-3-3969-1534 FAX : 81-3-3969-9354
 EMAIL : overseas@tok-bearing.co.jp

Product specification are subject to change without prior notice.
Before assembly or use of any bearing, please read "Caution for Use"

K-SERIES BEARINGS



THE K-SERIES BEARING

- 1.The K-Series bearing can be provided with an assortment of materials and colors, depending on the applications. Along with acetal resins, other resins can be used based on lubricity, wear resistance, and weight reduction.
- 2.The K-Series bearing uses a lubricious plastic for its outer race, which enables integral molding of timing gears, pulleys, and etc; it is then press fitted along the periphery of the bearing.
- 3.The K-Series bearing is a specialty bearing and is designed per customer requirements and specifications.

BASIC SIZES

Bore diameter [mm]	Basic outside diameter ^{*1} [mm]	Basic width [mm]
4	16 ≤	4 ≤
5	16 ≤	4 ≤
6	16 ≤	7 ≤
7	18 ≤	7 ≤
8	18.5 ≤	7 ≤
9	24 ≤	7 ≤
10	24 ≤	7 ≤

*1 Root diameter for gear.

APPLICATIONS

- Wire pulleys
- Tension pulleys
- Sprocket gears
- Timing gears
- Involute gears

DESIGN CONDITIONS TO BE PREARRANGED

- Maximum working load
- Maximum number of revolutions while running
- Applications (objectives, working mechanisms etc.)
- Environment

DESIGN EXAMPLE

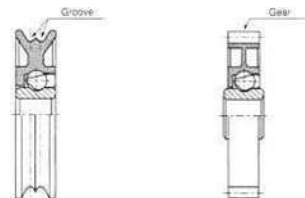

TOK BEARING CO.,LTD.

HEAD OFFICE, TOKYO, JAPAN – TEL : 81-3-3969-1534 FAX : 81-3-3969-9354
EMAIL : overseas@tok-bearing.co.jp

Product specification are subject to change without prior notice.

Before assembly or use of any bearing, please read "Caution for Use"

TOK BEARING CO.,LTD.

ONE-WAY CLUTCHES



Adding functions to customized housings assist in providing cost reductions.

(PAT.P)

Features

1. Wide range of various functions
2. Space saving compact design
3. A consistent and high clutching Torque
4. A shaft with a integral formed bearing
5. A wide range of available shafts
6. A wide range of shaft materials

Applications

Copy machines, fax machines, Printers, all-in one office machine's packaging machines, postage machines, vending machines, cash registers, blinds and other feeding equipment for paper and tapes.

1. STANDARD SPECIFICATIONS

TCM SERIES (Metal Spring Type)

Application Shaft [mm]	Element Type Number	Allowable Torque [N·m] (kgf·cm)	Free Torque [mN·m] (gf·cm)	Locking Direction (SHAFT FIXED)
$\phi 3_{-0.025}^0$	TCM-310-B	0.08	2.94 \geq	CCW
	TCM-310-RB	(0.8)	(30) \geq	CW
$\phi 4_{-0.03}^0$	TCM-412-6-B	0.18	2.94 \geq	CCW
	TCM-412-6-RB	(1.8)	(30) \geq	CW
$\phi 5_{-0.03}^0$	TCM-513-B	0.29 (3)	2.94 \geq (30) \geq	CCW
$\phi 6_{-0.03}^0$	TCM-613-B-No.14	0.34	3.92 \geq	CCW
	TCM-613-RB-No.14	(3.5)	(40) \geq	CW
	TCM-614-AB	0.49	2.94 \geq	CCW
	TCM-614-ARB	(5)	(30) \geq	CW
	TCM-616-AB	0.59	2.94 \geq	CCW
	TCM-616-ARB	(6)	(30) \geq	CW
$\phi 6.35_{-0.03}^0$	TCM-6.35-B	0.59	2.94 \geq	CCW
	TCM-6.35-RB	(6)	(30) \geq	CW
$\phi 8_{-0.036}^0$	TCM-816-AB	0.64	2.94 \geq	CCW
	TCM-816-ARB	(6.5)	(30) \geq	CW
	TCM-818-AB	0.78	2.94 \geq	CCW
	TCM-818-ARB	(8)	(30) \geq	CW
$\phi 10_{-0.036}^0$	TCM-1022-AB	0.98	2.94 \geq	CCW
	TCM-1022-ARB	(10)	(30) \geq	CW

TCM-H (Metal Spring Type/Heat Resistance)

Application Shaft [mm]	Element Type Number	Allowable Torque [N·m] (kgf·cm)	Free Torque [mN·m] (gf·cm)	Locking Direction (SHAFT FIXED)
$\phi 8_{-0.036}^0$	TCM-818-AB-H	0.78 (8)	2.94 \geq (30) \geq	CCW

TCX SERIES (Plastic Spring Type)

Application Shaft [mm]	Element Type Number	Allowable Torque [N·m] (kgf·cm)	Free Torque [mN·m] (gf·cm)	Locking Direction (SHAFT FIXED)
$\phi 6_{-0.03}^0$	TCX-614-AB	0.39	4.90 \geq	CCW
	TCX-614-ARB	(4)	(50) \geq	CW
$\phi 8_{-0.036}^0$	TCX-816-AB	0.54	4.90 \geq	CCW
	TCX-816-ARB	(5.5)	(50) \geq	CW

4. TEST RESULTS

Test conditions

- (1) Engagement cycle : 240 cycles/minute
- (2) Oscillation angle: 30 degrees
- (3) Radial load : 9.8N (1Kgf)
- (4) Shaft material: ASTM W1-10
- (5) Shaft tolerance zone: JIS h9 or more
- (6) Surface Hardness: 700Hv

- Note : 1. After 1,000,000 engagement test with a rated torques load, every TCM and TCX clutch had a slight increase in back-lash, but was within the company's standards of 2.5 degrees.
2. Applied torque for measuring back-lash : 0.098N·m(1Kgf·cm)

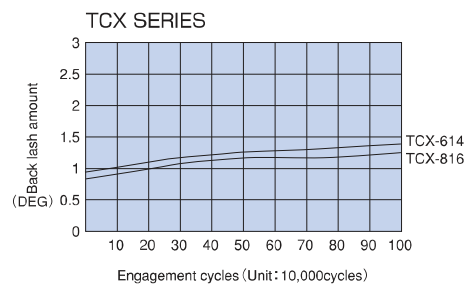
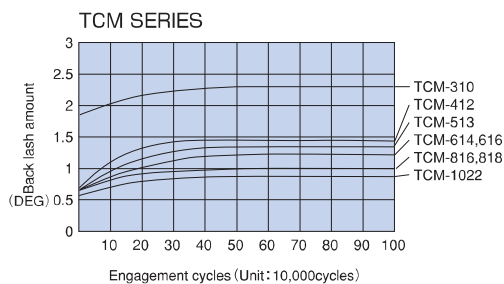

5. RECOMMENDED SHAFT SPECIFICATIONS

When inserting the shaft into a uni-directional clutch, turn the clutch in the direction of the free rotation. Any sharp edge around the shaft use be chamfered or removed. The above test was achieved using a grounded shaft of bearing steel, hardened to 600 to 800 Hv. Stainless Steel and free cutting steel may also be used in standard operating conditions.

Note:

Operating temperature: 0 degrees C to 60 degrees C (For higher temperature use, please contact our sales/engineering department).

Some surface treatments to the shaft may reduce clutch functions

Low surface hardness or soft materials may reduce the full life of the clutch, only use materials that are recommended by our engineering department.

In order to avoid improper operation or malfunctions do not use the uni-directional clutch under these conditions:

1. Direct vibration from machines
2. void shaft sliding due to axial force
3. The use of solid lubricants
4. In high dust areas

TOK BEARING CO.,LTD.

TORQUE LIMITERS



By using a tension mechanism, Torque limiters prevents accidental over torque during operations

Features

1. Variable torque selection.
2. Compact and lightweight

Applications

Copy machines, faxes, printers and other automated equipment.



[Torque Limiters]

1. Standard operation temperatures 0 degrees C to 40 degrees C
(For higher temperatures, please contact our sales/engineering departments)
2. Water and Oil will effect the torque limiters by causing slippage of the torque and malfunction of the limiters.
3. During installation do not subject the Limiters housing to axial and/or radial load.
4. Any direct radial load could cause torque variation.
5. Rotate only in the uni-directional direction. (CW or CCW)



TORQUE LIMITERS

TLE

TLE SERIES

The TLE SERIES TORQUE LIMITERS generates Hysteresis torque between a permanent magnet and a semi-rigid magnetic substance. If speed dependency or temperature dependency play factor in your choice, the TLE SERIES TORQUE LIMITERS out performs a spring type limiters. In applications of non contact with a permanent magnet or magnetic substance the TLE SERIES TORQUE LIMITERS are an excellent choice for durability compared to slide resistance systems (spring type limiters) and multi-plate type of limiters.

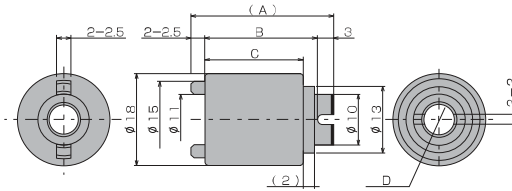

- FEATURES
- 1.Fluctuations of torque due to rotational speed changes are reduced.
 - 2.Fluctuations of torque due to temperature and humidity changes are reduced.
 - 3.Fluctuations of torque in CW and CCW are reduced.
 - 4.Minimum torque differential between starting torque and dynamic torque.

Code	Part No.	Application shaft [mm]	(500min ⁻¹) Torque [mN·m] (gf·cm)	Rotating Direction	Basic dimensions [mm]			
					A	B	C	D
540001	TLE1-618-20W	φ 6	20 (204)	CW · CCW	19.5	14	11.5	φ 6
540002	TLE2-618-30W	φ 6	30 (306)	CW · CCW	22.5	17	14.5	φ 6
540003	TLE3-618-40W	φ 6	40 (408)	CW · CCW	26	20.5	18	φ 6

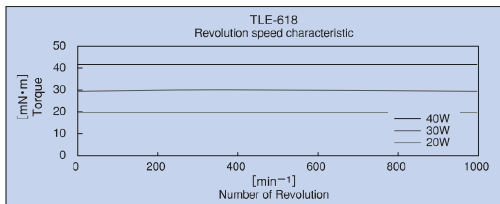

Rotational speed changes causes almost zero torque fluctuations. Due to slice resistance of the resin parts, there will be some noticeable speed dependencies.

Larger torque relates to larger speed dependencies

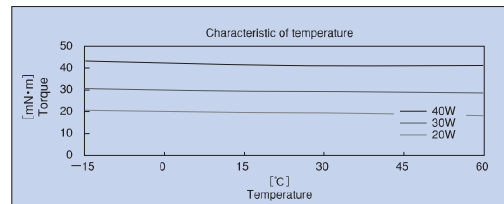

Temperature changes causes almost zero torque fluctuations. You will see a slight torque reduction due to lower temperatures effecting the magnetic components, recovery will occur at room temperature.

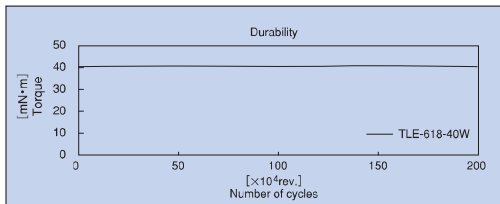

At low rotational speeds, there is very little wear on the TLE SERIES TORQUE LIMITERS. As conditions dictate and wear increases, the permanent magnet and the semi-rigid magnetic surface will come in contact, reducing the durability of the limiter.

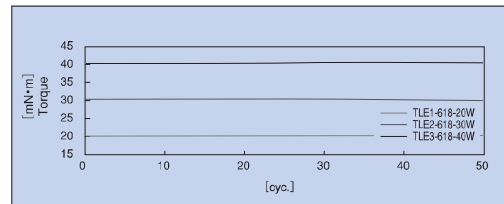

Annealing the resin parts increases the longevity of the parts.

TOK BEARING CO.,LTD.

HEAD OFFICE, TOKYO, JAPAN - TEL : 81-3-3969-1534 FAX : 81-3-3969-9354
EMAIL : overseas@tok-bearing.co.jp

Product specification are subject to change without prior notice.

Before assembly or use of any bearing, please read "Caution for Use"

TOK BEARING CO., LTD.

ROTARY DAMPERS



Rotary dampers provide safe, quiet closing and a feeling of luxury.

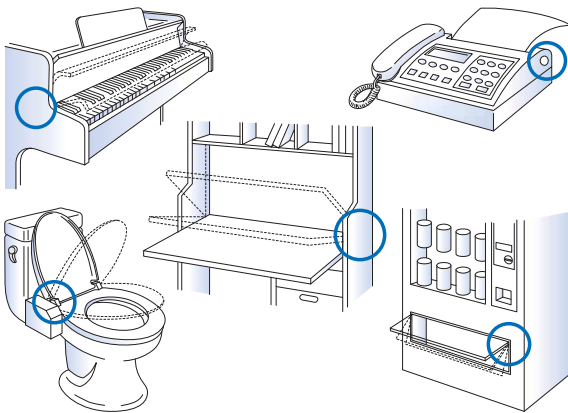

Applications

1. Copy machines, faxes, printers, and other office automation equipment.
2. Pianos, toilet seats, air conditioners
3. Furniture, drawers, vending machines, refrigerators and other appliances.

Rotary dampers provide a full range of motion where quiet running and smooth motion is desired.



CAUTION!

Be sure to read before use!

In order to use and handle these products in a safe and reliable manner and to prevent oil leaks, poor torque, breakage, personal injury, or damage to equipment, please read the preceding notes carefully.

1. During installation insure that proper installation load is used.
Installation load is the rate of safety X the torque applied.
2. Do not operate without any external (mechanical) stopper.
When using the finite angle type of damper position the stopper within the operational angle of the damper and avoid using only the damper without a mechanical stopper.
3. Do not operate above the allowable torque, or on systems that close in less than one (1) second* using external forces.
4. Do not operate outside the operation temperature range.
5. Other conditions:
 - a. Void contact with organic solvents (such as thinner, ether, etc) or their environments.
 - b. If radial/axial forces are added to the shaft, possible oil leaks, reduced torque, and breakage could occur.

*Standard of our company.

ROTARY DAMPERS

FINITE ANGLE TYPE

Code	torque lineup	torque value (kgf · cm)									damper size (mm)				
		1	10	20	30	40	50	~	90	10	20	30	40 ~		
TD73	1K·2K·3K	■										■			
TD75	1K·2K·3K	■										■			
TD38	1.5K·3K·6K	■	■									■	■		
TD14	10K·15K·20K		■	■								■	■		
TD60	10K·15K·20K		■	■								■	■		
TD27	5K~20K		■	■								■	■		
TD56	15K·20K·25K·30K			■	■							■	■		
TD63	15K·20K·25K			■	■							■	■		
TD69	20K·25K·30K·35K				■	■						■	■		
TD22	25K·40K					■	■					■	■		
TD42	50K·70K·90K									■	■	■	■		

INFINITE ANGLE TYPE

Code	torque lineup	torque value (kgf · cm)									damper size (mm)				
		0	1	2	3	4	5	6	7	8	10	20	30	40 ~	
TD62	0.3/0.6/0.9/1.5/2.0K		■	■								■	■		
TD58	3K·5K·8K				■	■	■	■	■	■		■	■		

Calculation of torque (reference for selection of torque value)

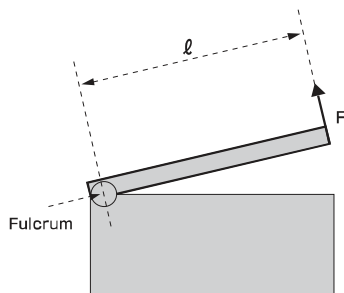

W : Weight of cover (kg)

l : Distance between fulcrum and cover opening edge [m]

F : Gravity force [N]

T : Torque to be required [N · m]

$$T = W \times 9.8 \times \frac{l}{2} \text{ [N · m]} \text{ or } T = F(\text{MAX}) \times l \text{ [N · m]}$$

TOK BEARING CO.,LTD.

HEAD OFFICE, TOKYO, JAPAN – TEL : 81-3-3969-1534 FAX : 81-3-3969-9354
EMAIL : overseas@tok-bearing.co.jp

Product specification are subject to change without prior notice.

Before assembly or use of any bearing, please read "Caution for Use"

ROTARY DAMPERS

Dimension table for installing in counter parts (Recommendation)

Part No.	For housing				For shaft		Allowable radial force [N] (kgf)
	A	B	C	D	E	F	
TD73	5 ^{+0.06} / _{+0.01}	φ 6 ^{+0.06} / _{+0.01}	—	—	5 ^{+0.06} / _{+0.01}	φ 6 ^{+0.06} / _{+0.01}	9.8 [N] (1kgf)
TD75	5 ^{+0.06} / _{+0.01}	φ 6 ^{+0.06} / _{+0.01}	9.2 ^{+0.06} / _{+0.01}	—	5 ^{+0.06} / _{+0.01}	φ 6 ^{+0.06} / _{+0.01}	9.8 [N] (1kgf)
TD14	8 ^{+0.07} / _{+0.01}	φ 18 ^{+0.07} / _{+0.01}	—	—	8 ^{+0.07} / _{+0.01}	φ 12 ^{+0.07} / _{+0.01}	29.4 [N] (3kgf)
TD56	8 ^{+0.07} / _{+0.01}	φ 18 ^{+0.07} / _{+0.01}	—	—	6 ^{+0.07} / _{+0.01}	φ 8 ^{+0.07} / _{+0.01}	29.4 [N] (3kgf)
TD69	8 ^{+0.06} / _{+0.01}	φ 16 ^{+0.40} / _{+0.35}	φ 20 ^{+0.06} / _{+0.01}	—	8 ^{+0.06} / _{+0.01}	φ 12 ^{+0.06} / _{+0.01}	29.4 [N] (3kgf)
TD22	10 ^{+0.11} / _{+0.06}	(4)	9 ^{+0.06} / _{+0.01}	φ 16.2 ^{+0.16} / _{+0.11}	7 ^{+0.06} / _{+0.01}	φ 10 ^{+0.06} / _{+0.01}	19.6 [N] (2kgf)
TD27 TD28	20 ^{±0.1}	16 ^{+0.3} / ₀	(18)	36 ^{±0.1}	7.5 ^{+0.16} / _{+0.06}	φ 14 ^{+0.16} / _{+0.06}	P1 : 29.4 [N] (3kgf) P2 : 39.2 [N] (4kgf)
TD38	34 ^{±0.1}	φ 22.3 ^{±0.1}	M4	—	5 ^{+0.06} / _{+0.01}	φ 6 ^{+0.06} / _{+0.01}	29.4 [N] (3kgf)
TD42	56 ^{±0.1}	φ 41 ^{±0.2}	φ 5.3	—	8 ^{+0.07} / _{+0.01}	φ 12 ^{+0.07} / _{+0.01}	9.8 [N] (1kgf)
TD62	36 ^{±0.3}	φ 25 ^{+0.1} / ₀	M3	—	—	—	13.4 [N] (1.37kgf)
TD58	44 ^{±0.3}	φ 32 ^{±0.2}	M4	—	—	—	13.4 [N] (1.37kgf)
TD60	43.4 ^{+0.06} / _{+0.01}	26.8 ^{+0.06} / _{+0.01}	34 ^{±0.1}	M4	8 ^{+0.07} / _{+0.01}	φ 10 ^{+0.07} / _{+0.01}	29.4 [N] (3kgf)
TD63	34 ^{±0.1}	12 ^{+0.3} / ₀	M4	φ 25 ^{+0.5} / _{+0.4}	8 ^{+0.07} / _{+0.01}	φ 12 ^{+0.07} / _{+0.01}	29.4 [N] (3kgf)

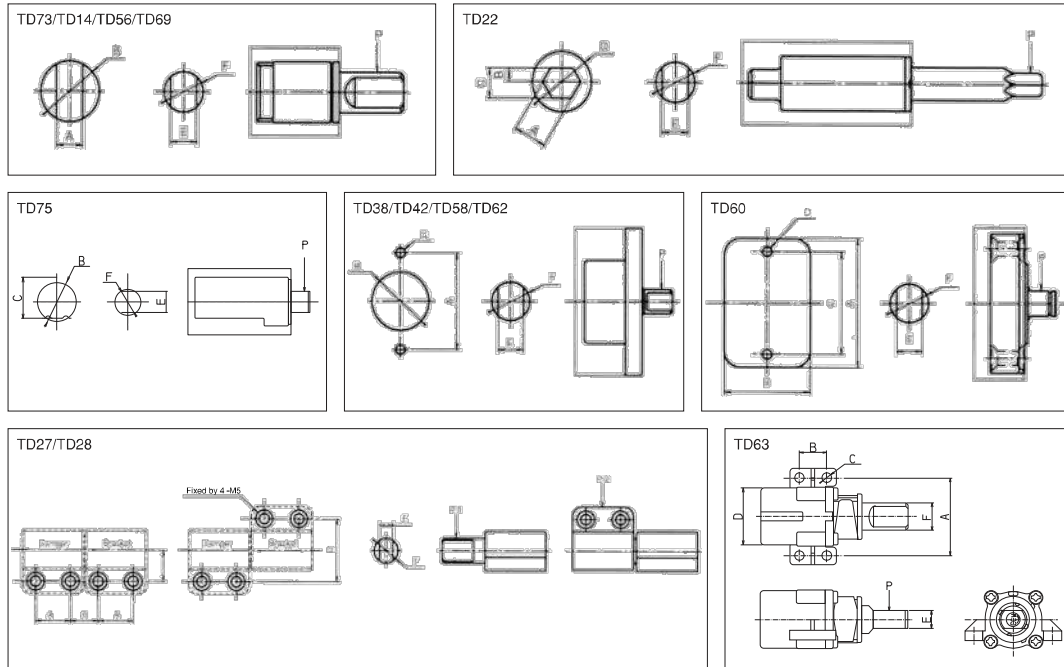

TOK BEARING CO.,LTD.

HEAD OFFICE, TOKYO, JAPAN — TEL : 81-3-3969-1534 FAX : 81-3-3969-9354
EMAIL : overseas@tok-bearing.co.jp

Product specification are subject to change without prior notice.
Before assembly or use of any bearing, please read "Caution for Use"

ROTARY DAMPERS

TD69 SERIES

COMPACT AND HIGH-TORQUE AND HEAT RESISTANCE



- FEATURES**
- RoHS Compliance
 - Possible to use in the high temperature of 80°C owing to super engineering plastic.
 - Achieved the torque of 3.43N·m for outer diameter 20mm.

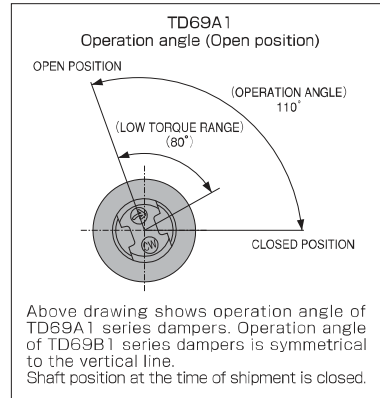
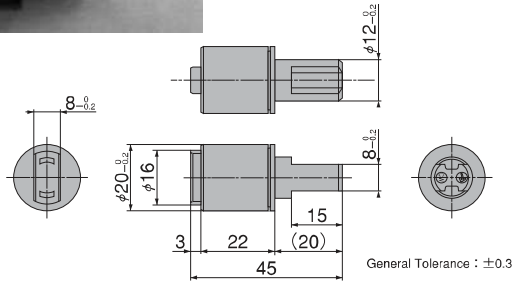

Code	Part No.	Allowable Torque [N·m] (Kgf·cm)	Direction
606906	TD69A1-20K	[1.96] (20)	CW (R)
606904	TD69A1-25K	[2.45] (25)	CW (R)
606902	TD69A1-30K	[2.94] (30)	CW (R)
606900	TD69A1-35K	[3.43] (35)	CW (R)

Code	Part No.	Allowable Torque [N·m] (Kgf·cm)	Direction
606907	TD69B1-20K	[1.96] (20)	CCW (L)
606905	TD69B1-25K	[2.45] (25)	CCW (L)
606903	TD69B1-30K	[2.94] (30)	CCW (L)
606901	TD69B1-35K	[3.43] (35)	CCW (L)

DURABILITY

Each damper is set-up with an applied torque and weight on the shaft of the testing device. Measurements for closing time are taken under above condition.

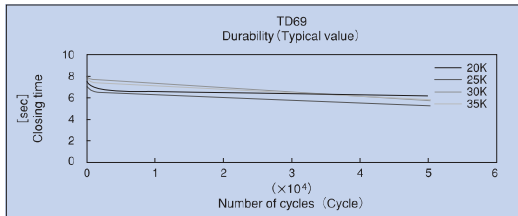

Operation angle	110°															
Durability	50,000cycles															
Closing time	<table border="1"> <thead> <tr> <th>range of operation temperature</th> <th>Applied torque</th> <th>Initial value</th> </tr> </thead> <tbody> <tr> <td>-5~80 [°C]</td> <td>1.96N·m (20kgf·cm)</td> <td>3~12 (sec)</td> </tr> <tr> <td>-5~80 [°C]</td> <td>2.45N·m (25kgf·cm)</td> <td>3~12 (sec)</td> </tr> <tr> <td>-5~80 [°C]</td> <td>2.94N·m (30kgf·cm)</td> <td>3~12 (sec)</td> </tr> <tr> <td>-5~50 [°C]</td> <td>3.43N·m (35kgf·cm)</td> <td>3~12 (sec)</td> </tr> </tbody> </table>	range of operation temperature	Applied torque	Initial value	-5~80 [°C]	1.96N·m (20kgf·cm)	3~12 (sec)	-5~80 [°C]	2.45N·m (25kgf·cm)	3~12 (sec)	-5~80 [°C]	2.94N·m (30kgf·cm)	3~12 (sec)	-5~50 [°C]	3.43N·m (35kgf·cm)	3~12 (sec)
	range of operation temperature	Applied torque	Initial value													
	-5~80 [°C]	1.96N·m (20kgf·cm)	3~12 (sec)													
	-5~80 [°C]	2.45N·m (25kgf·cm)	3~12 (sec)													
-5~80 [°C]	2.94N·m (30kgf·cm)	3~12 (sec)														
-5~50 [°C]	3.43N·m (35kgf·cm)	3~12 (sec)														

TEMPERATURE CHARACTERISTICS

After the damper is stabilized at room temperature for 1 hour or more, the closing time is measured using a TOK made device.

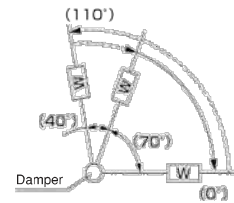
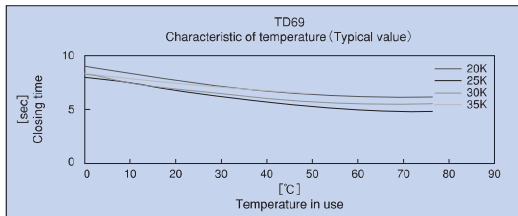

TEST CONDITION

- ① Setting-up time : 15sec/cycle
- ② Applied torque : 1.96N·m (20kgf·cm)
2.45N·m (30kgf·cm)
2.94N·m (25kgf·cm)
3.43N·m (35kgf·cm)
- ③ Temp : 23°C±2°C 1.96N·m (20kgf·cm)
2.94N·m (30kgf·cm)
80°C±2°C 2.45N·m (25kgf·cm)
50°C±2°C 3.43N·m (35kgf·cm)
- ④ Angle for measuring the closing time : 70°→0°
- ⑤ Radial force : nothing
- ⑥ Closing time after durability test : 1 sec or more

TOK BEARING CO.,LTD.

HEAD OFFICE, TOKYO, JAPAN - TEL : 81-3-3969-1534 FAX : 81-3-3969-9354
EMAIL : overseas@tok-bearing.co.jp

Product specification are subject to change without prior notice.
Before assembly or use of any bearing, please read "Caution for Use"

ROTARY DAMPERS

TD73 SERIES

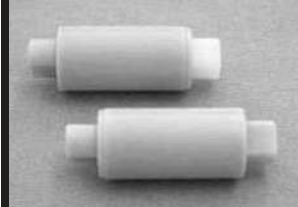

FEATURES

- RoHS compliance
- TD73 DAMPERS have outer diameter of 11mm and housing length of 22mm with maximum torque
- 0.29N·m (3kgf·cm) that realized in compact configuration.

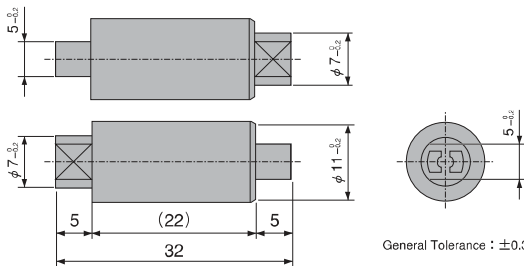

General Tolerance : ± 0.3

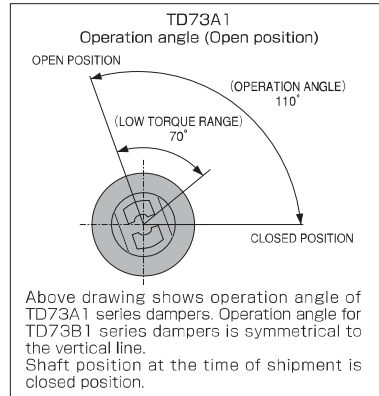

Code	Part No.	Allowable Torque [N·m] (Kgf·cm)	Direction
607304	TD73A1-1K	[0.10] (1)	CW(R)
607302	TD73A1-2K	[0.20] (2)	CW(R)
607300	TD73A1-3K	[0.29] (3)	CW(R)

Code	Part No.	Allowable Torque [N·m] (Kgf·cm)	Direction
607305	TD73B1-1K	[0.10] (1)	CCW(L)
607303	TD73B1-2K	[0.20] (2)	CCW(L)
607301	TD73B1-3K	[0.29] (3)	CCW(L)

DURABILITY

Each damper is set-up with an applied torque and weight on the shaft of the testing device. Measurements for closing time are taken under above condition.

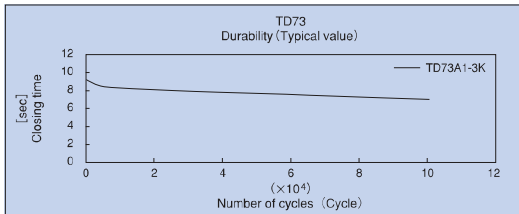

Operation angle	110°	
Durability	100,000cycles	
Closing time	Applied torque	Initial value
	0.10N·m (1kgf·cm)	2~10 (sec)
	0.20N·m (2kgf·cm)	2~10 (sec)
	0.29N·m (3kgf·cm)	5~15 (sec)

TEMPERATURE CHARACTERISTICS

After the damper is stabilized at room temperature for 1 hour or more, the closing time is measured using a TOK made device.

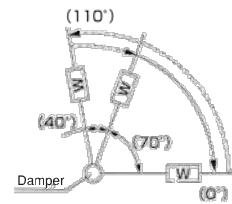
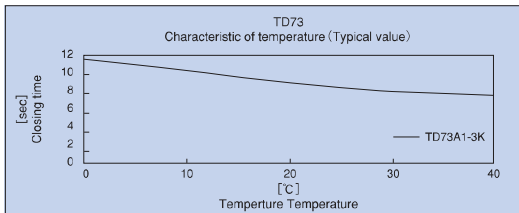

TEST CONDITION

- ① Setting-up time : 15sec/cycle
- ② Applied torque : 0.10N·m (1kgf·cm)
0.20N·m (2kgf·cm)
0.29N·m (3kgf·cm)
- ③ Temp : 23°C \pm 2°C
- ④ Angle for measuring the closing time : 70° \rightarrow 0°
- ⑤ Radial force : nothing
- ⑥ Closing time after durability test : 1 sec or more

TOK BEARING CO.,LTD.

HEAD OFFICE, TOKYO, JAPAN – TEL : 81-3-3969-1534 FAX : 81-3-3969-9354
EMAIL : overseas@tok-bearing.co.jp

Product specification are subject to change without prior notice.
Before assembly or use of any bearing, please read "Caution for Use"

ROTARY DAMPERS

TD75 SERIES



FEATURES

- RoHS compliance
- For High Temperature applications of 80 degrees C, high temperature engineered plastics can be used.
- Achieved torque of 3.43N·m for outer diameter of 20mm

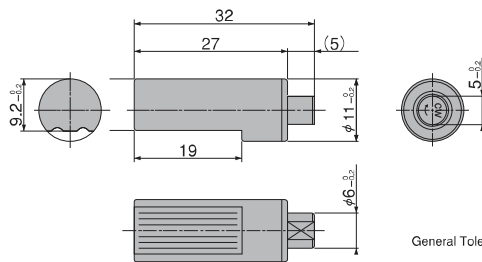

General Tolerance : ±0.3

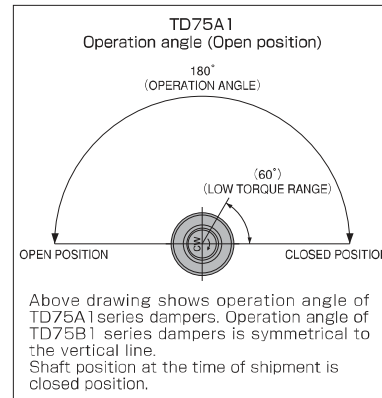

Code	Part No.	Allowable Torque [N·m] (Kgf·cm)	Direction
607504	TD75A1-1K	[0.10] (1)	CW (R)
607502	TD75A1-2K	[0.20] (2)	CW (R)
607500	TD75A1-3K	[0.29] (3)	CW (R)

Code	Part No.	Allowable Torque [N·m] (Kgf·cm)	Direction
607505	TD75B1-1K	[0.10] (1)	CCW (L)
607503	TD75B1-2K	[0.20] (2)	CCW (L)
607501	TD75B1-3K	[0.29] (3)	CCW (L)

DURABILITY

Each damper is set-up with an applied torque and weight on the shaft of the testing device. Measurements for closing time are taken under above condition.

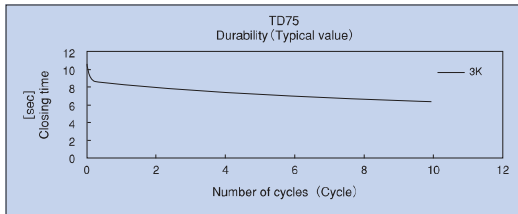

Operation angle	180°	
Durability	100,000cycles	
Closing time	Applied torque	Initial value
	0.1 N·m (1kgf·cm)	5~15 (sec)
	0.20N·m (2kgf·cm)	5~15 (sec)
	0.29N·m (3kgf·cm)	5~15 (sec)

TEMPERATURE CHARACTERISTICS

After the damper is stabilized at room temperature for 1 hour or more, the closing time is measured using a TOK made device.

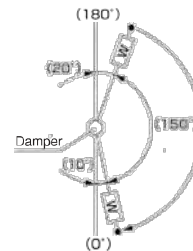
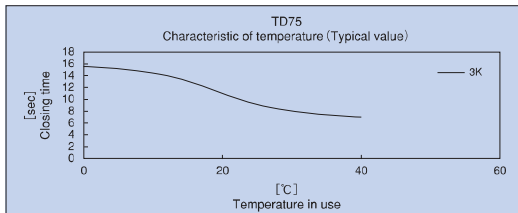

TEST CONDITION

- ① Setting-up time : 15sec/cycle
- ② Applied torque : 0.29N·m (3kgf·cm)
- ③ Temp : 23°C±2°C
- ④ Angle for measuring the closing time : 160°~10°
- ⑤ Radial force : nothing
- ⑥ Closing time after durability test : 1 sec or more

ROTARY DAMPERS

TD27/28 SERIES

TD27



TD28



FEATURES

- RoHS compliance
- TD27/28 DAMPERS have the torque adjustment device and torque adjustment of TD27/28 DAMPERS is easy.
- By combining with exclusive brackets, TD27/28 DAMPERS can be used as hinges.

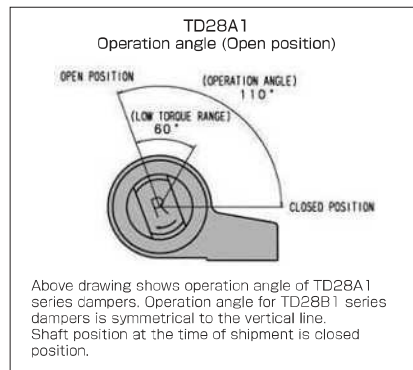
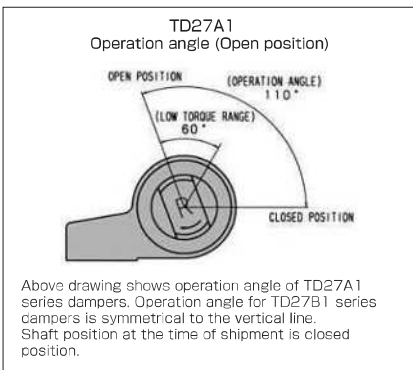
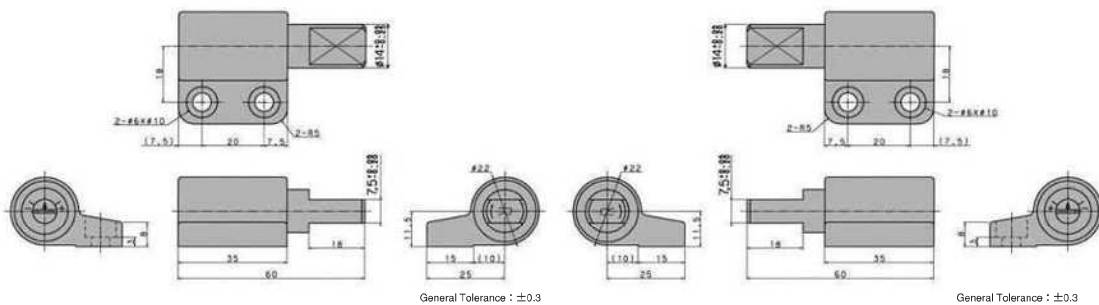

Code	Part No.	Allowable Torque [N·m] (Kgf·cm)	Direction
600270	TD27A1-5/13K	[0.49~1.27] (5~13)	CW (R)
600271	TD27B1-5/13K		CCW (L)
600272	TD27A1-10/20K	[0.98~1.96] (10~20)	CW (R)
600273	TD27B1-10/20K		CCW (L)

Code	Part No.	Allowable Torque [N·m] (Kgf·cm)	Direction
600280	TD28A1-5/13K	[0.49~1.27] (5~13)	CW (R)
600281	TD28B1-5/13K		CCW (L)
600282	TD28A1-10/20K	[0.98~1.96] (10~20)	CW (R)
600283	TD28B1-10/20K		CCW (L)

TOK BEARING CO.,LTD.

HEAD OFFICE, TOKYO, JAPAN - TEL : 81-3-3969-1534 FAX : 81-3-3969-9354
EMAIL : overseas@tok-bearing.co.jp

Product specification are subject to change without prior notice.
Before assembly or use of any bearing, please read "Caution for Use"

ROTARY DAMPERS

DURABILITY

Each damper is set-up with an applied torque and weight on the shaft of the testing device. Measurements for closing time are taken under above condition.

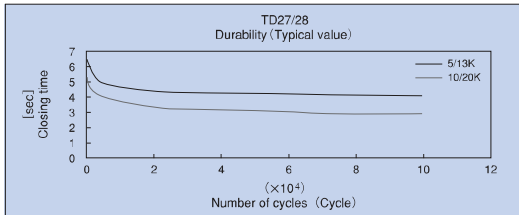

Operation angle	110°	
Durability	100,000cycles	
Closing time	Applied torque	Initial value
	1.27N·m (13kgf·cm)	3.5~15.0 (sec)
	1.96N·m (20kgf·cm)	3.5~15.0 (sec)

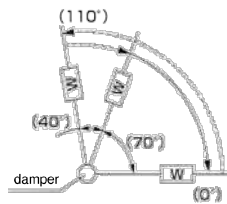

TEMPERATURE CHARACTERISTICS

After the damper is stabilized at room temperature for 1 hour or more, the closing time is measured using a TOK made device.

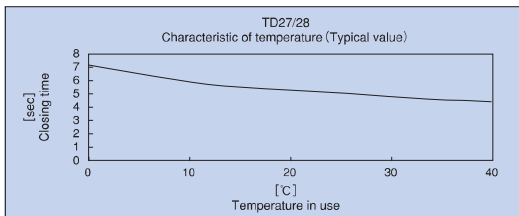

TEST CONDITION

- ① Setting-up time : 15sec/cycle
- ② Applied torque :
1.27N·m (13kgf·cm)
1.96N·m (20kgf·cm)
- ③ Temp : 23°C±2°C
- ④ Angle for measuring the closing time : 70°→0°
- ⑤ Radial force : nothing
- ⑥ Closing time after durability test : 1.5 sec or more

TD27/28 Bracket (Option)

Combination of TD27(orTD28)and the optional bracket are used to form a hinge-shaped damper.



Combination example :

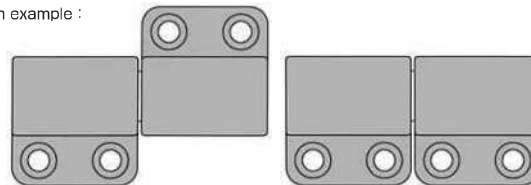

The bracket cap can be removed for use on either the right side fit or left side fit. To insure optimum cap condition, removal of the cap should be kept to a minimum.

ROTARY DAMPERS

TD56 SERIES



FEATURES

- RoHS compliance
- TD56 DAMPERS have a device which reduces back-lash and continues to exhibit a positive damping effect.
- TD56 DAMPER permits 2.94N+m of maximum torque.

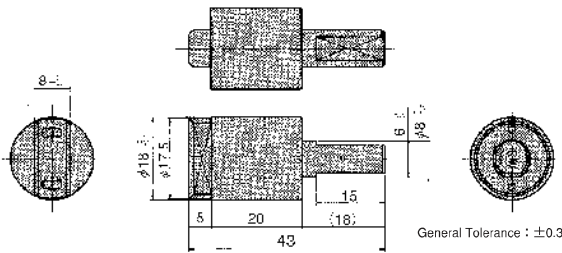
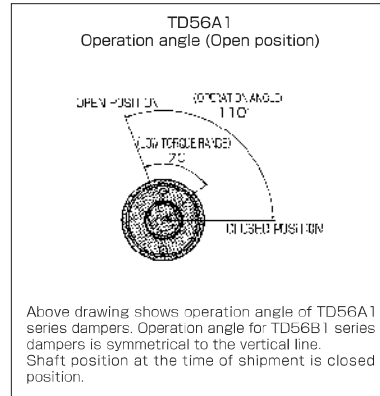

Code	Part No.	Allowable Torque [N·m] (Kgf·cm)	Direction
605608	TD56A1-15K	[1.47] (15)	CW(R)
605606	TD56A1-20K	[1.96] (20)	CW(R)
605604	TD56A1-25K	[2.45] (25)	CW(R)
605600	TD56A1-30K	[2.94] (30)	CW(R)

Code	Part No.	Allowable Torque [N·m] (Kgf·cm)	Direction
605609	TD56B1-15K	[1.47] (15)	CCW(L)
605607	TD56B1-20K	[1.96] (20)	CCW(L)
605605	TD56B1-25K	[2.45] (25)	CCW(L)
605601	TD56B1-30K	[2.94] (30)	CCW(L)

DURABILITY

Each damper is set-up with an applied torque and weight on the shaft of the testing device. Measurements for closing time are taken under above condition.

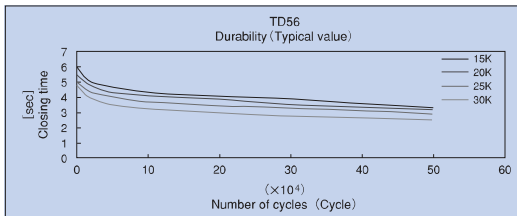

Operation angle	110°	
Durability	50,000cycles	
Closing time	Applied torque	Initial value
	1.47N·m (15kgf·cm)	3~10 (sec)
	1.96N·m (20kgf·cm)	3~10 (sec)
	2.45N·m (25kgf·cm)	3~10 (sec)
2.94N·m (30kgf·cm)	3~10 (sec)	

TEMPERATURE CHARACTERISTICS

After the damper is stabilized at room temperature for 1 hour or more, the closing time is measured using a TOK made device.

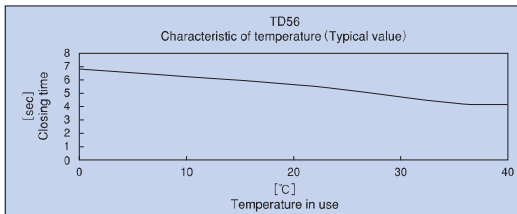

TEST CONDITION

- ①Setting-up time : 15sec/cycle
- ②Applied torque :
 - 1.47N·m (15kgf·cm)
 - 1.96N·m (20kgf·cm)
 - 2.45N·m (25kgf·cm)
 - 2.94N·m (30kgf·cm)
- ③Temp : 23°C±2°C
- ④Angle for measuring the closing time : 70°→0°
- ⑤Radial force : nothing
- ⑥Closing time after durability test : 1 sec or more

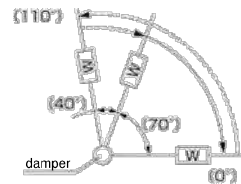

TOK BEARING CO.,LTD.

HEAD OFFICE, TOKYO, JAPAN – TEL : 81-3-3969-1534 FAX : 81-3-3969-9354
EMAIL : overseas@tok-bearing.co.jp

Product specification are subject to change without prior notice.
Before assembly or use of any bearing, please read "Caution for Use"

ROTARY DAMPERS

TD22 SERIES



FEATURES

- RoHS compliance
- Even with the compact size of the outer diameter 16.2, the torque value of 3.92N+m is achieved.

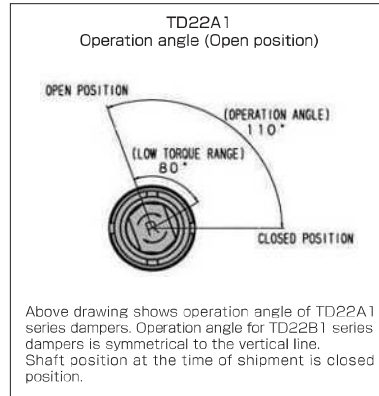
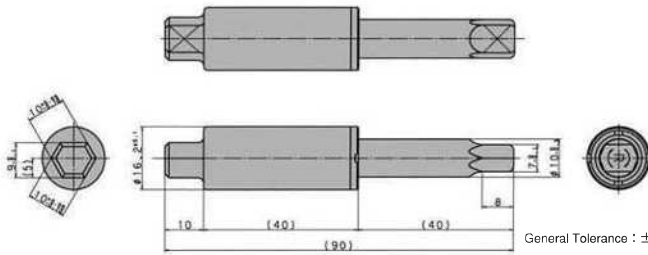

Code	Part No.	Allowable Torque [N·m] (Kgf·cm)	Direction
600220	TD22A1-25K	[2.45] (25)	CW(R)
600226	TD22A1-40K	[3.92] (40)	CW(R)

Code	Part No.	Allowable Torque [N·m] (Kgf·cm)	Direction
600221	TD22B1-25K	[2.45] (25)	CCW(L)
600223	TD22B1-40K	[3.92] (40)	CCW(L)

DURABILITY

Each damper is set-up with an applied torque and weight on the shaft of the testing device. Measurements for closing time are taken under above condition.

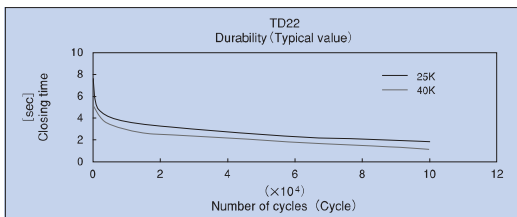

Operation angle	110°	
Durability	100,000cycles	
Closing time	Applied torque	Initial value
	2.45N·m (25kgf·cm)	4~18 (sec)
	3.92N·m (40kgf·cm)	4~18 (sec)

TEMPERATURE CHARACTERISTICS

After the damper is stabilized at room temperature for 1 hour or more, the closing time is measured using a TOK made device.

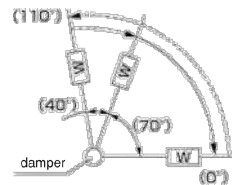
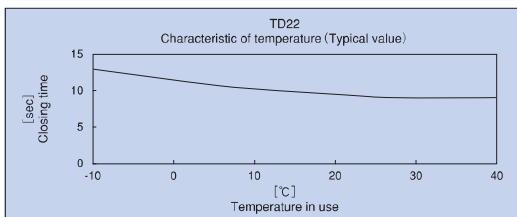

TEST CONDION

- ①Setting-up time : 25sec./cycle
- ②Applied torque :
2.45N·m (25kgf·cm)
3.92N·m (40kgf·cm)
- ③Temp : 23°C±2°C
- ④Angle for measuring the closing time : 70°→0°
- ⑤Radial force : nothing
- ⑥Closing time after durability test : 1 sec or more

TOK BEARING CO.,LTD.

HEAD OFFICE, TOKYO, JAPAN – TEL : 81-3-3969-1534 FAX : 81-3-3969-9354
EMAIL : overseas@tok-bearing.co.jp

Product specification are subject to change without prior notice.

Before assembly or use of any bearing, please read "Caution for Use"

ROTARY DAMPERS

TD42 SERIES



FEATURES

- RoHS compliance
- TD42 DAMPERS have a device which reduces backlash and continues to exhibit a positive damping effect.
- TD56 DAMPERS permits 8.82N+m of maximum torque.

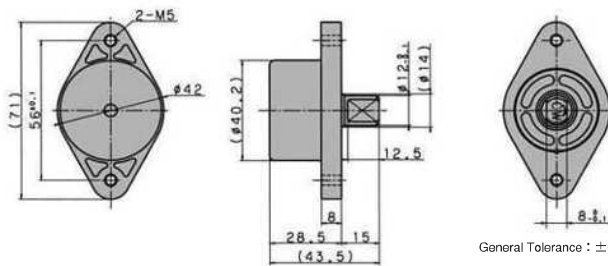

General Tolerance : ± 0.2

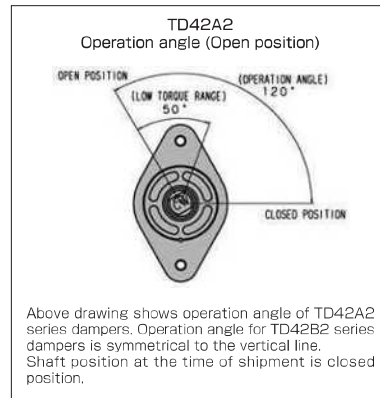

Code	Part No.	Allowable Torque [N·m] (Kgf·cm)	Direction
604201	TD42A2-50K	[4.90] (50)	CW(R)
600426	TD42A2-70K	[6.86] (70)	CW(R)
604203	TD42A2-90K	[8.83] (90)	CW(R)

Code	Part No.	Allowable Torque [N·m] (Kgf·cm)	Direction
604202	TD42B2-50K	[4.90] (50)	CCW(L)
600427	TD42B2-70K	[6.86] (70)	CCW(L)
604204	TD42B2-90K	[8.83] (90)	CCW(L)

DURABILITY

Each damper is set-up with an applied torque and weight on the shaft of the testing device. Measurements for closing time are taken under above condition.

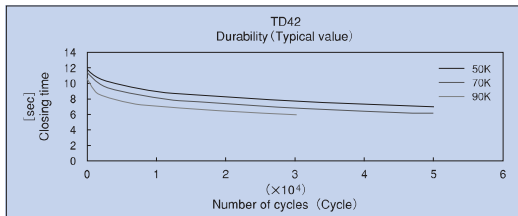

Operation angle	120°	
Durability	TD42A2/B2-50K	50,000cycles
	TD42A2/B2-70K	50,000cycles
	TD42A2/B2-90K	50,000cycles
Closing time	Applied torque	Initial value
	4.90N·m (50kgf·cm)	5~25 (sec)
	6.86N·m (70kgf·cm)	5~25 (sec)
	8.83N·m (90kgf·cm)	5~25 (sec)

TEMPERATURE CHARACTERISTICS

After the damper is stabilized at room temperature for 1 hour or more, the closing time is measured using a TOK made device.

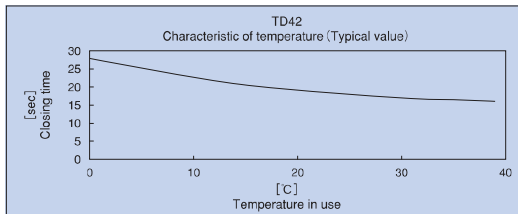

TEST CONDITION

- ① Setting-up time : 20sec/cycle
- ② Applied torque :
 - 4.90N·m (50kgf·cm)
 - 6.86N·m (70kgf·cm)
 - 8.83N·m (90kgf·cm)
- ③ Temp : 23°C \pm 2°C
- ④ Angle for measuring the closing time : 90° \rightarrow 0°
- ⑤ Radial force : nothing
- ⑥ Closing time after durability test :
 - 4.90N·m/2.5sec or more
 - 6.86N·m/2.5sec or more
 - 8.83N·m/2.0sec or more

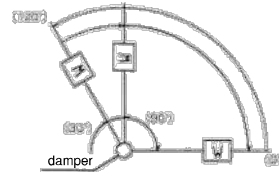

TOK BEARING CO.,LTD.

HEAD OFFICE, TOKYO, JAPAN – TEL : 81-3-3969-1534 FAX : 81-3-3969-9354
EMAIL : overseas@tok-bearing.co.jp

Product specification are subject to change without prior notice.
Before assembly or use of any bearing, please read "Caution for Use"

ROTARY DAMPERS

TD60 SERIES



FEATURES

- RoHS compliance
- This design combines a body width of 10.9mm and a torque of 1.96N+m.

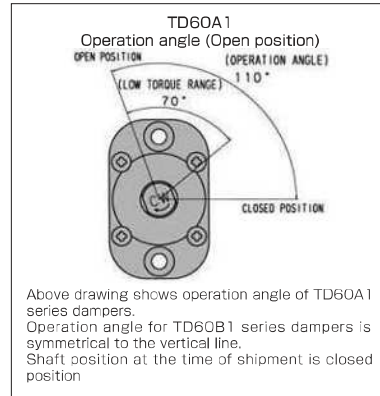
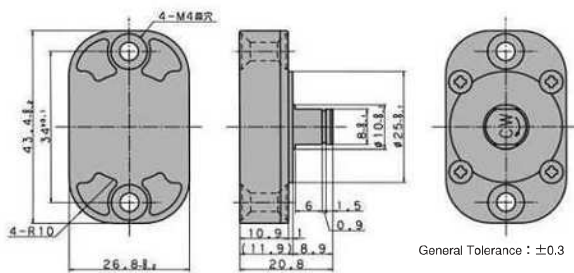

Code	Part No.	Allowable Torque [N·m] (Kgf·cm)	Direction
606005	TD60A1-10K	[0.98] (10)	CW(R)
606003	TD60A1-15K	[1.47] (15)	CW(R)
606001	TD60A1-20K	[1.96] (20)	CW(R)

Code	Part No.	Allowable Torque [N·m] (Kgf·cm)	Direction
606006	TD60B1-10K	[0.98] (10)	CCW(L)
606004	TD60B1-15K	[1.47] (15)	CCW(L)
606002	TD60B1-20K	[1.96] (20)	CCW(L)

DURABILITY

Each damper is set-up with an applied torque and weight on the shaft of the testing device. Measurements for closing time are taken under above condition.

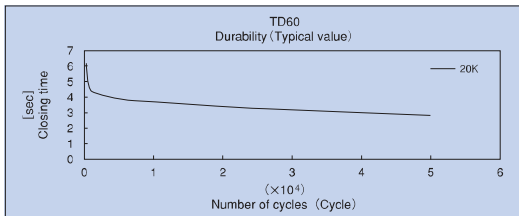

Operation angle	110°	
Durability	50,000cycles	
Closing time	Applied torque	Initial value
	0.98N·m (10kgf·cm)	5~15 (sec)
	1.47N·m (15kgf·cm)	5~15 (sec)
	1.96N·m (20kgf·cm)	3~12 (sec)

TEMPERATURE CHARACTERISTICS

After the damper is stabilized at room temperature for 1 hour or more, the closing time is measured using a TOK made device.

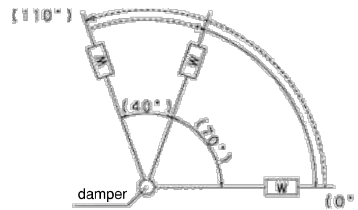
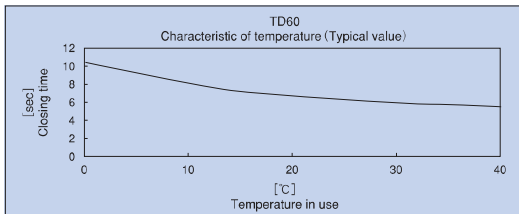

TEST CONDITION

- ①Setting-up time : 15sec/cycle
- ②Applied torque :
 - 0.98N·m (10kgf·cm)
 - 1.47N·m (15kgf·cm)
 - 1.96N·m (20kgf·cm)
- ③Temp : 23°C±2°C
- ④Angle for measuring the closing time : 70°→0°
- ⑤Radial force : nothing
- ⑥Closing time after durability test : 1 sec or more

ROTARY DAMPERS

TD38 SERIES



FEATURES

- RoHS compliance
- TD38 DAMPERS realized operation angle 180°.
- TD38 DAMPERS can be fixed to the system firmly with screws and are easy to install.

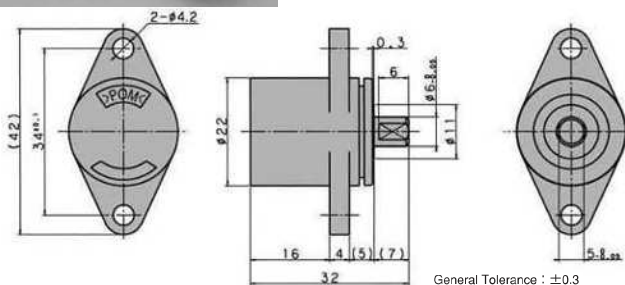
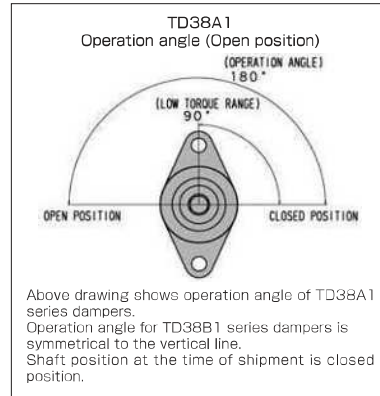

Code	Part No.	Allowable Torque [N·m] (Kgf·cm)	Direction
600382	TD38A1-1.5K	[0.15] (1.5)	CW (R)
600380	TD38A1-3K	[0.29] (3.0)	CW (R)
600384	TD38A1-6K	[0.59] (6.0)	CW (R)

Code	Part No.	Allowable Torque [N·m] (Kgf·cm)	Direction
600383	TD38B1-1.5K	[0.15] (1.5)	CCW (L)
600381	TD38B1-3K	[0.29] (3.0)	CCW (L)
600385	TD38B1-6K	[0.59] (6.0)	CCW (L)

DURABILITY

Each damper is set-up with an applied torque and weight on the shaft of the testing device. Measurements for closing time are taken under above condition.

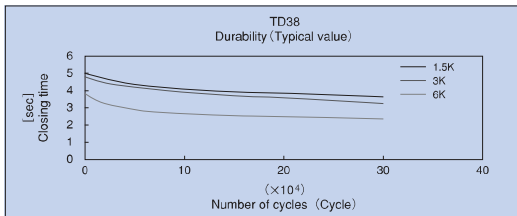

Operation angle	180°	
Durability	300,000cycles	
Closing time	Applied torque	Initial value
	0.15N·m (1.5kgf·cm)	2~10 (sec)
	0.29N·m (3.0kgf·cm)	2~10 (sec)
	0.59N·m (6.0kgf·cm)	2~10 (sec)

TEMPERATURE CHARACTERISTICS

After the damper is stabilized at room temperature for 1 hour or more, the closing time is measured using a TOK made device.

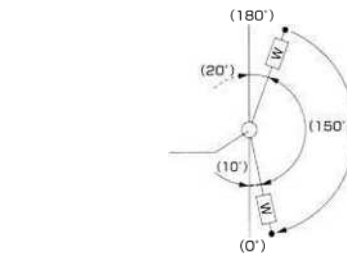
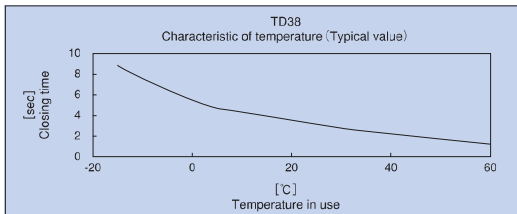

TEST CONDITION

- ①Setting-up time : 15sec/cycle
- ②Applied torque :
0.15N·m (1.5kgf·cm)
0.29N·m (3.0kgf·cm)
0.59N·m (6.0kgf·cm)
- ③Temp : 23°C±2°C
- ④Angle for measuring the closing time : 160°→10°
- ⑤Radial force : nothing
- ⑥Closing time after durability test : 1 sec or more

TOK BEARING CO.,LTD.

HEAD OFFICE, TOKYO, JAPAN – TEL : 81-3-3969-1534 FAX : 81-3-3969-9354
EMAIL : overseas@tok-bearing.co.jp

Product specification are subject to change without prior notice.

Before assembly or use of any bearing, please read "Caution for Use"

ROTARY DAMPERS

TD62 SERIES



FEATURES
 · RoHS compliance
 · Wide range of torque

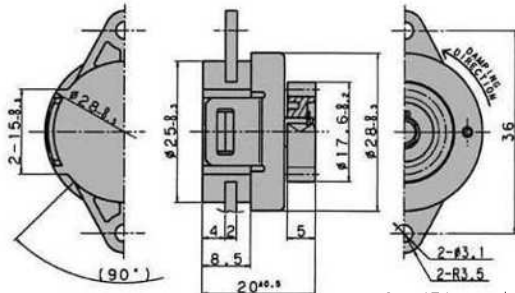

General Tolerance : ±0.3

Code	Part No.	Torque [mN·m] (gf·cm)	Direction	(min ⁻¹) Allowable revolution speed
606217	TD62R1-300	[30] (310)	CW (R)	80
606218	TD62L1-300		CCW (L)	
606219	TD62R1-600	[60] (610)	CW (R)	80
606220	TD62L1-600		CCW (L)	
606222	TD62R1-900	[90] (920)	CW (R)	70
606221	TD62L1-900		CCW (L)	
606226	TD62R1-1500	[150] (1530)	CW (R)	50
606225	TD62L1-1500		CCW (L)	
606228	TD62R1-2000	[200] (2040)	CW (R)	50
606227	TD62L1-2000		CCW (L)	
*606236	TD62W1-600	[60] (610)	CW (R)	80
*606237	TD62W1-1500	[150] (1530)	CCW (L)	50

☆Bidirection type. Able to supply. TD62 with different torque.
 ※CW (R) → Damping effect is available when the gear is rotated in CW. (Cap color: Dark grey)
 ※CCW (L) → Damping effect is available when the gear is rotated in CCW. (Cap color: Grey)

Gear Specification	
Profile of Gear	Standard Spur Gear
Tooth Profile	Full Depth Tooth
Module	1
Pressure Angle	20°
Number of Teeth	5
P.C.D. [mm]	φ15
Shift	+0.3
Displacement over given Number of Teeth [mm]	4.84/2

DURABILITY

The torque is measured by a TOK made device at 30min⁻¹ (30 rpm)

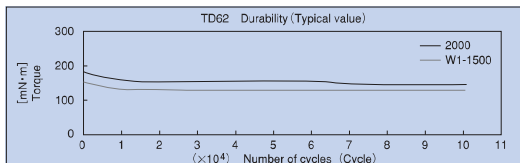

Durability		100,000cycles	
Part No.	[mN·m]	Initial torque [gf·cm]	(min ⁻¹) Revolution speed
TD62R1/L1-300	[21~39]	(214~397)	30
TD62R1/L1-600	[45~75]	(459~765)	
TD62R1/L1-900	[72~108]	(734~1,102)	
TD62R1/L1-1500	[120~180]	(1,224~1,836)	
TD62R1/L1-2000	[160~240]	(1,632~2,448)	
TD62W1-600	[45~75]	(459~765)	
TD62W1-1500	[120~180]	(1,224~1,836)	

SPEED REVOLUTION CHARACTERISTICS

Measurements of torque are taken after each revolution per minute using the TOK-made device for measuring Torque.

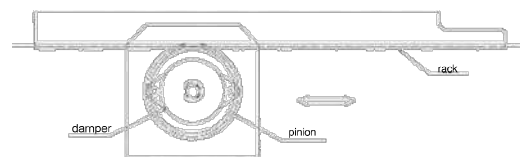
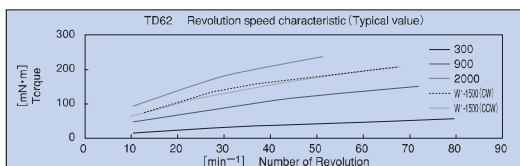

TEMPERATURE CHARACTERISTICS

After the damper is stabilized at room temperature for 1 hour or more, the torque at 30min⁻¹ (30rpm) is measured using a TOK made device.

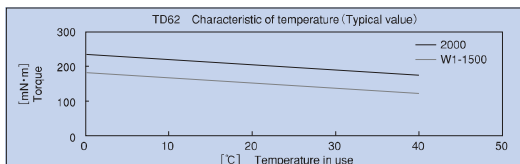

TEST CONDITION

- ① Test method : Gear test by rack and pinion
- ② Number of cycle : 100,000cycles
- ③ Length of rack : $l=50$ mm
- ④ Moving speed : 24mm/sec
- ⑤ Revolution per minute : 30min⁻¹
- ⑥ Pinion : Same as the above gear specification
- ⑦ Facial force : 5N(0.5kgf · cm)
- ⑧ Torque after the test : 0.12N·m or more (30min⁻¹)
- ⑨ Number of revolution per cycle : approx 1 rev.(one-way)

TOK BEARING CO.,LTD.

HEAD OFFICE, TOKYO, JAPAN – TEL : 81-3-3969-1534 FAX : 81-3-3969-9354
 EMAIL : overseas@tok-bearing.co.jp

Product specification are subject to change without prior notice.
Before assembly or use of any bearing, please read "Caution for Use"

ROTARY DAMPERS

TD58 SERIES



- FEATURES**
- RoHS compliance
 - Even as an infinite angle damper a 0.80N·m of maximum torque can be achieved.
 - A bi-directional TD58 DAMPER can also be manufactured.

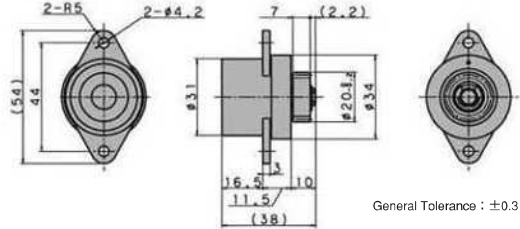

Code	Part No.	Torque [N·m] (Kgf·cm)	Direction	Allowable revolution speed (min ⁻¹)
605806	TD58R1-3K	[0.30] (3.1)	CW (R)	100
605807	TD58L1-3K		CCW (L)	
605804	TD58R1-5K	[0.50] (5.1)	CW (R)	60
605805	TD58L1-5K		CCW (L)	
605801	TD58R1-8K	[0.80] (8.2)	CW (R)	30
605802	TD58L1-8K		CCW (L)	

* CW (R) ...Damping effect is available when the gear is rotated in CW. (Cap color: Dark gray)
 CCW (L) ...Damping effect is available when the gear is rotated in CCW. (Cap color: Grey)

Gear Specification	
Profile of Gear	Standard Spur Gear
Tooth Profile	Full Depth Tooth
Module	1
Pressure Angle	20°
Number of Teeth	18
P.C.D. [mm]	φ18
Displacement over given Number of Teeth [mm]	7.63/3

DURABILITY

The torque is measured by a TOK made device at 30min⁻¹ (30rpm)

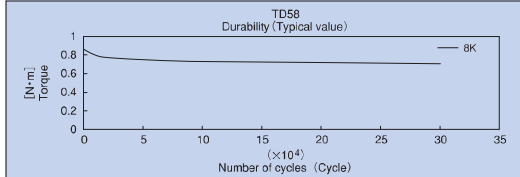

Durability	200,000cycles	
Part No.	Initial torque [N·m] (Kgf·cm)	(min ⁻¹) Revolution speed
TD58R1/L1-3K	[0.24~0.36] (2.35~3.53)	30
TD58R1/L1-5K	[0.40~0.60] (3.92~5.88)	
TD58R1/L1-8K	[0.64~0.96] (6.27~9.41)	

SPEED REVOLUTION CHARACTERISTICS

Measurements of torque are taken after each revolution per minute using the TOK-made device for measuring Torque.

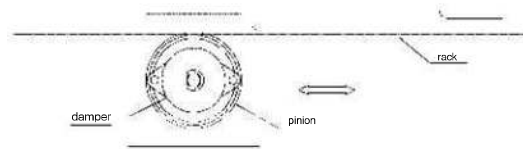
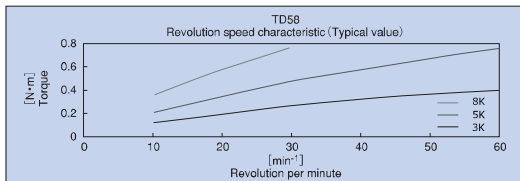

TEMPERATURE CHARACTERISTICS

After the damper is stabilized at room temperature for 1 hour or more, the torque at 30min⁻¹ (30rpm) is measured using a TOK made device.

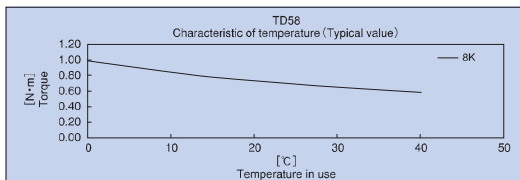

TEST CONDITION

- ① Test method : Gear test by rack and pinion
- ② Number of cycle : 200,000cycles
- ③ Length of rack : $l=180\text{mm}$
- ④ Moving speed : 75mm/sec
- ⑤ Revolution per minute : 30min⁻¹
- ⑥ Pinion... P.C.D=φ48mm
Module=1.5
Number of teeth=32
- ⑦ Radial force : 13.4N(1.37kgf·cm)
- ⑧ Torque after the test : 0.5N·m or more (30min⁻¹)
- ⑨ Number of revolution per cycle : approx 1.2 rev.(one-way)

TOK BEARING CO.,LTD.

HEAD OFFICE, TOKYO, JAPAN – TEL : 81-3-3969-1534 FAX : 81-3-3969-9354
 EMAIL : overseas@tok-bearing.co.jp

Product specification are subject to change without prior notice.
Before assembly or use of any bearing, please read "Caution for Use"

ROTARY DAMPERS

New Product Lineup

TD88 SERIES

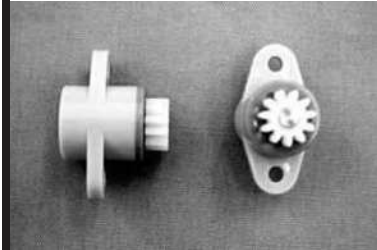

FEATURES

- RoHS compliance
- One direction and compact size
- High durability

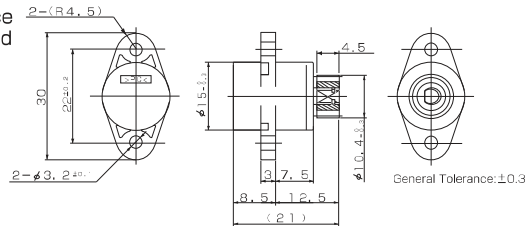

Code	Part No.	Allowable Torque [mN·m] (gf·cm)	Direction
608800	TD88R1-400	[40] (410)	CW (R)
608810	TD88L1-400	[40] (410)	CCW (L)

※Applicable in the different torque.
 ※Bidirection type of TD88 DAMPERS can also be manufactured.

Gear Specification	
Profile of Gear	Standard Spur Gear
Tooth Profile	Full Depth Tooth
Module	0.8
Pressure Angle	20°
Number of Teeth	1
P.C.D. [mm]	φ8.8
Shift	-
Displacement over given Number of Teeth [mm]	3.67/2

TD90 SERIES



FEATURES

- RoHS compliance
- Eliminates pinch points, fingers and hands. (upper lid support and assistance)
- Simple installation and attachment.
- Can be installed without attachment to the cover.

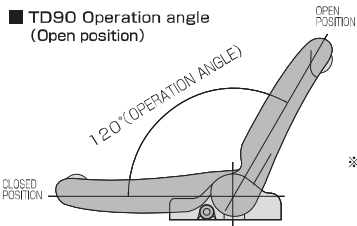

Code	Part No.	Allowable Torque [N·m] (kgf·cm)	Direction
609000	TD90B1-20K	[19.6] (20)	CCW (L)

※Please ask for available colors.

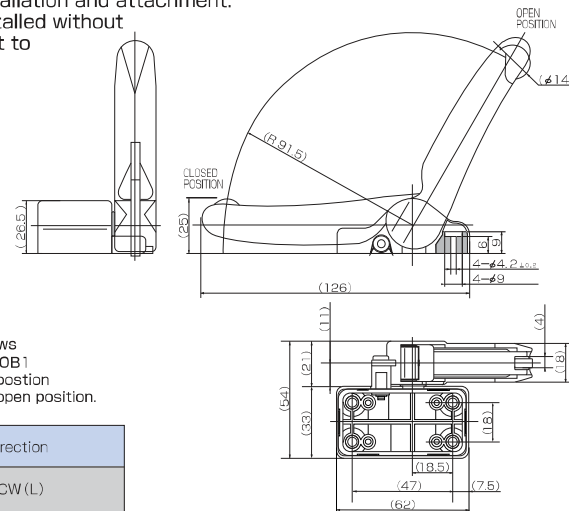

TOK BEARING CO.,LTD.

HEAD OFFICE, TOKYO, JAPAN - TEL : 81-3-3969-1534 FAX : 81-3-3969-9354
 EMAIL : overseas@tok-bearing.co.jp

Product specification are subject to change without prior notice.
Before assembly or use of any bearing, please read "Caution for Use"

ROTARY DAMPERS

New Product Lineup

TD89 SERIES



- FEATURES**
- RoHS compliance
 - TOK maximum torque damper
 - Easy to install because of the small size of the hinge

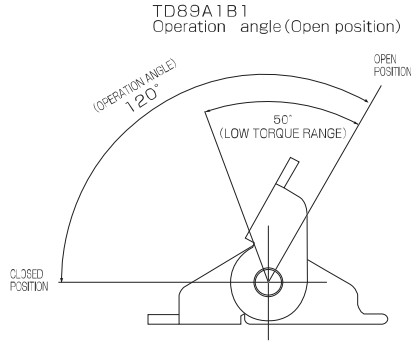

※ Above drawing shows operation angle of TD89A1B1 series dampers. Shaft position of shipment is closed position.

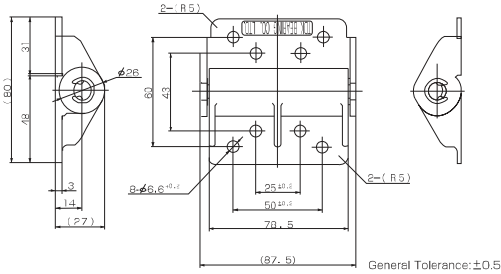

Code	Part No.	Allowable Torque [N·m] (kgf·cm)	Direction
608900	TD89A1B1-100K	[10.0] (100)	※Refer to the drawing of the operation angle on the right.

※ Available in the different torque
 ※ Please contact our engineer if the opposite damping direction is required.

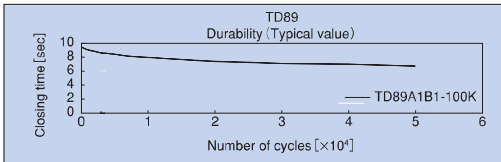

DURABILITY

Each damper is set-up with an applied torque and weight on the shaft of the testing device. Measurements for closing time are taken under above condition.

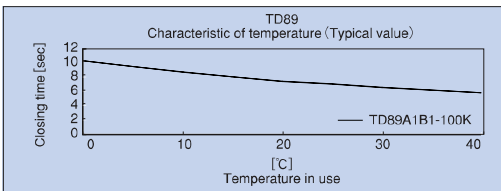

TEMPERATURE CHARACTERISTICS

After the damper is stabilized at room temperature for 1 hour or more, the closing time is measured using a TOK made device.

Operation angle	120°	
Durability	50,000cycles	
Closing time	Applied torque 10.0N·m (100kgf·cm)	Initial Value 3~12sec

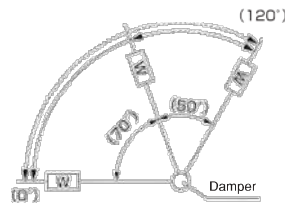

TEST CONDITION

- ① Setting-up time : 20sec/time
- ② Applied torque : 10.0N·m (100kgf·cm)
- ③ Temp : 23°C±2°C
- ④ Angle for measuring the closing time : 70°→0°
- ⑤ Radial force : nothing
- ⑥ Closing time after durability test : 1 sec or more

TOK BEARING CO., LTD.

PLALINEAR®/ PLALINEAR MOTION®

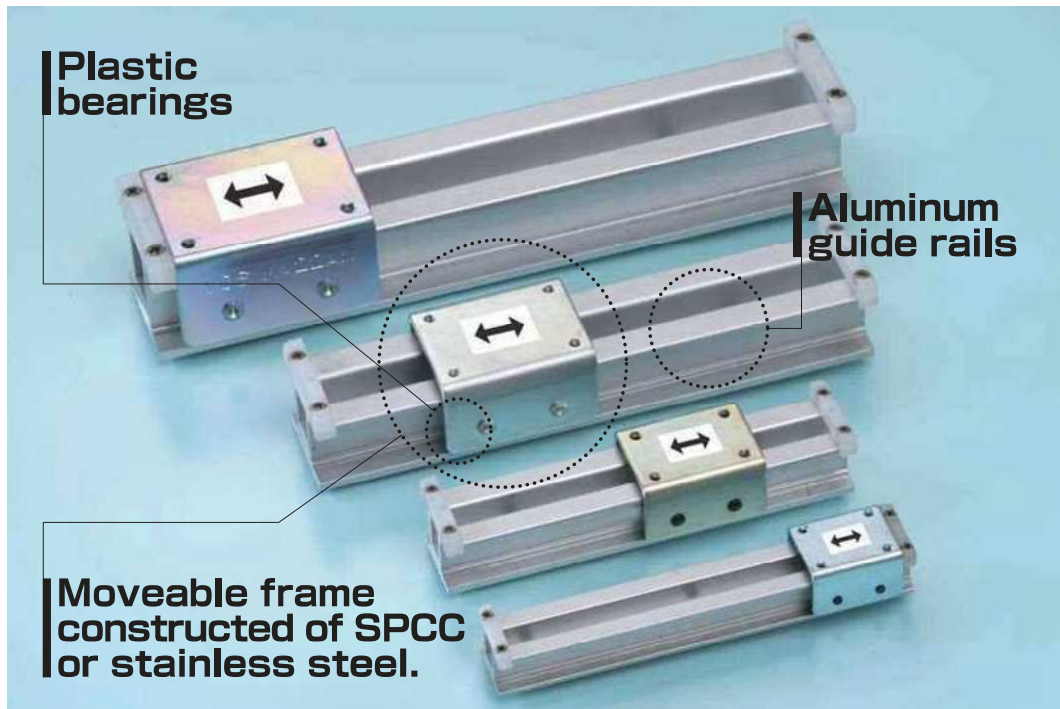

The Latest edition of a linear bearing provides cost reduction.

Conventional precision direct-drive bearings are constructed of steel and are used in high-load operations. These bearings are often very expensive for specific applications and need proper maintenance to maintain their durability, keep them clean and to protect them against corrosion. PLALINEAR direct-drive bearings were designed and engineered to overcome many of the conventional issues and problems but still provide exceptional quality at a lower cost, and offer a construction that can be used in clean environments.

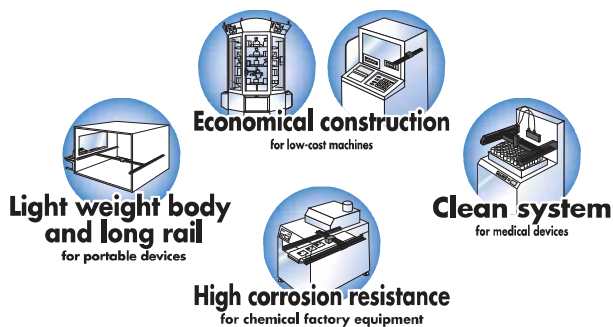

Applications

Plalinear can be used for a variety of machinery, such as factory equipment, office equipment, arcade games, food processing machines, packaging machines, cleaning machines, medical equipment, testing and measuring machines, and transport equipment., etc.

Features

① Economical construction

PLALINEAR uses low-cost plastic ball bearings and various other components to create a cost-effective bearing system that is less than 50% the cost of a conventional system.

② Light weight body and long rails:

By using lightweight components, our system weights approximately 20% of a conventional bearing system constructed of steel. Because of the lightweight it enables the use of longer rails.

③ Cleanliness Characteristics

PLALINEAR uses plastic balls which eliminates the lubricating oils, thus ensuring a clean environment.

④ Corrosion resistance

Rust and corrosion is eliminated by using plastic components, which ensure longer operational life of the bearing systems.

⑤ Easy maintenance

The actuator features a compact yet integrated construction to ensure easier maintenance.

Standard specifications

Part No.	Allowable Load (Load of vertical direction) [N]	(kgf)	Permission speed [m/min]	Accuracy	Durability
Type9	4.9	(0.5)	14	Above crevice : max 1mm	After 30,000 cycles, it is free of abnormal operation <Test condition> Test working distance : 500mm Applied Load : Allowable Load At Permission speed
Type12	9.8	(1.0)	19	Transverse direction crevice	
Type16	19.6	(2.0)	25	Standard type : max 2mm	
Type22	39.2	(4.0)	35	With a spacer : max 0.3mm	

Composition table

Moving

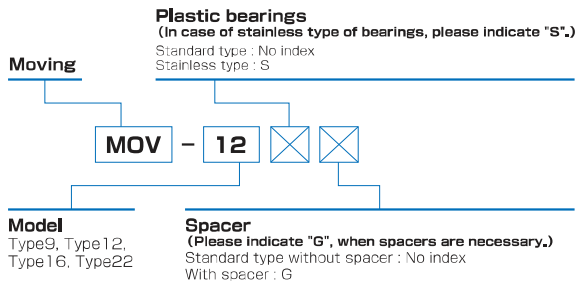

Rail

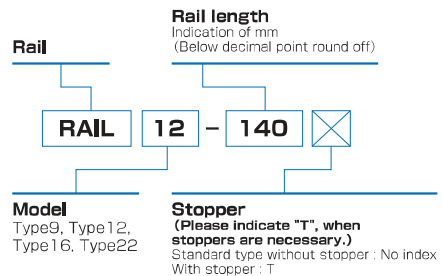

PLALINEAR® / PLALINEAR MOTION®



These basic bearing systems operate with an exterior drive and are available in four standard sizes.

No. 986766

MAIN COMPONENTS

No.	Item	Material and Specification
①	Moving chasis	ISO 3574(SPCC/JISG314) w/Zinc Plating or Stainless ISO 683(SUS304/JISG4305)
②	Bearing	D series or MD series bearings are used for Standard types. DR-S series bearings are used for Stainless.
③	Rail	Aluminum ISO 209(A6063/JISH4100)
④	Stopper	Polyethylene Resin (Movement is eliminated by installing the stopper)
⑤	Spacer	Polyacetal Resin (with a insert of a spacer between the movement and the rail, horizontal clearance will be reduced.)

NUMBERING SYSTEM OF A PLALINEARS

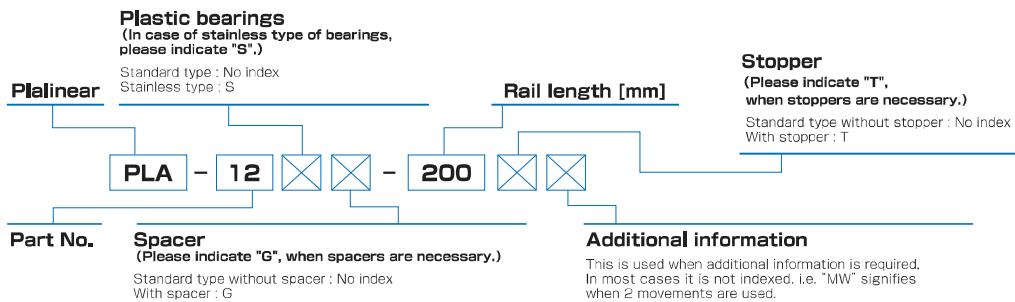

MEASUREMENT

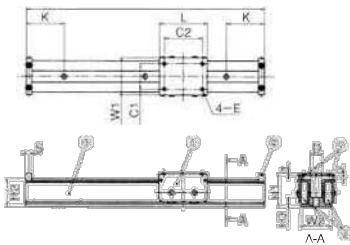

DIMENSION

Part No.	Height		Width		Length		Clearance			Stopper				Moving					Rail					Installation recommendation fixing screw
	H1	W1	L	G	S	C1	C2	t	4-E	W2	H2	H3	D	K	Installation recommendation fixing screw									
Type9	15.6	18.0	22	2.5	3.2	12	16	1.2	4-M2.5	14.6	11.8	4	5.2	10	M2.5									
Type12	20.0	22.8	30	2.5	4.0	14	22	1.6	4-M3	18.6	16.0	5	5.6	20	M3									
Type16	26.0	30.0	38	3.0	5.0	20	30	2.0	4-M3	24.0	20.9	8	8.0	30	M4									
Type22	33.5	38.0	50	4.0	6.0	25	40	2.0	4-M4	32.0	27.5	10	11.6	40	M5									

Part No.	Rail standard length										Custom-made specification	
	60	100	140	180	220	260	300	340	380	3,600 (3,600Max)	3,600 (3,600Max)	
Type9	60	100	140	180	220	260	300	340	380	3,600 (3,600Max)	3,600 (3,600Max)	
Type12	100	160	220	280	340	400	460	520	580	3,600 (3,600Max)	3,600 (3,600Max)	
Type16	140	220	300	380	460	540	620	700	780	3,600 (3,600Max)	3,600 (3,600Max)	
Type22	180	280	380	480	580	680	780	880	980	3,600 (3,600Max)	3,600 (3,600Max)	

● If your requirement needs rail lengths hole installations not listed, please contact our sales/engineering departments for assistance.

TOK BEARING CO.,LTD.

HEAD OFFICE, TOKYO, JAPAN - TEL : 81-3-3969-1534 FAX : 81-3-3969-9354
 EMAIL : oversea@tok-bearing.co.jp

Product specification are subject to change without prior notice.
Before assembly or use of any bearing, please read "Caution for Use"

PLALINEAR® / PLALINEAR MOTION®



By adding a drive motor control mechanism to the PLALINEAR, it will enable the system to operate in two horizontal directions.

No. 3010208

AN EXAMPLE OF A PLALINEAR MOTION DESIGN (UNI-DIRECTIONAL DRIVE)

Uni-directional drive
(With a motor)

Plastic bearings
(In case of stainless type of bearings, please indicate "S".)
Standard type : No index
Stainless type : S

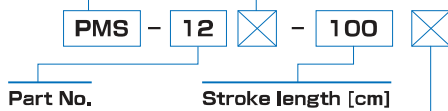

Additional information : This is used when additional information is required

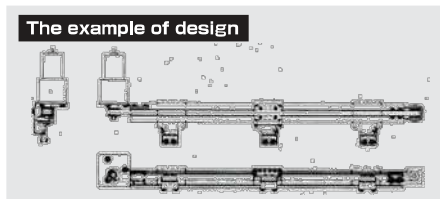

- Dimensions of the moving parts and rails are shown on the PLALINEAR dimensions.
- We will design and provide pricing for a customized stroke or any other desired operational characteristics.
- We can also provide power sources and control units.

AN EXAMPLE OF A PLALINEAR MOTION DESIGN (XY DRIVE)

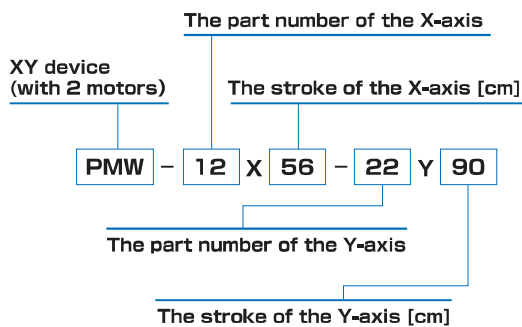

- Dimensions of the moving parts and rails are shown on the PLALINEAR dimensions.
- We will design and provide pricing for a customized stroke or any other desired operational characteristics.
- We can also provide power sources and control units.

